



## The Role of Landscape Architects in State Departments of Transportation: A Survey of State Practice

*Requested by*

Jennifer Taira, Senior Landscape Architect, Caltrans Landscape Architecture Program

May 15, 2015

*The Caltrans Division of Research, Innovation and System Information (DRISI) receives and evaluates numerous research problem statements for funding every year. DRISI conducts Preliminary Investigations on these problem statements to better scope and prioritize the proposed research in light of existing credible work on the topics nationally and internationally. Online and print sources for Preliminary Investigations include the National Cooperative Highway Research Program (NCHRP) and other Transportation Research Board (TRB) programs, the American Association of State Highway and Transportation Officials (AASHTO), the research and practices of other transportation agencies, and related academic and industry research. The views and conclusions in cited works, while generally peer reviewed or published by authoritative sources, may not be accepted without qualification by all experts in the field. The contents of this document reflect the views of the authors, who are responsible for the facts and accuracy of the data presented herein. The contents do not necessarily reflect the official views or policies of the California Department of Transportation, the State of California, or the Federal Highway Administration. This document does not constitute a standard, specification, or regulation. No part of this publication should be construed as an endorsement for a commercial product, manufacturer, contractor, or consultant. Any trade names or photos of commercial products appearing in this publication are for clarity only.*

### Table of Contents

<b>Executive Summary</b> .....	<b>2</b>
Background .....	2
Summary of Findings.....	2
Gaps in Findings.....	4
Next Steps .....	4
<b>Detailed Findings</b> .....	<b>5</b>
Survey Approach .....	5
Survey Results.....	6
<b>Appendices</b> .....	<b>17</b>
Appendix A: Full Survey Responses	
Appendix B: Florida DOT Highway Landscape, Beautification and Plan Review	
Appendix C: Florida DOT Position Description	
Appendix D: Landscape Architects and NYSDOT's Project Development Process	
Appendix E: Washington State DOT Certification of Documents by Licensed Professionals	
Appendix F: Oregon DOT Documents Requiring the Seal of Licensed Engineers, Land Surveyors, Geologists, Landscape Architects, and Photogrammetrists	

# Executive Summary

## **Background**

Caltrans is interested in an overview of the current state of the practice of landscape architects (LAs) by other state agencies.

To aid in this investigation, CTC & Associates surveyed six state DOTs—Florida, Nevada, New York, Oregon, Texas and Washington—that were selected by Caltrans as a sampling of LAs across the nation, asking questions in four topic areas related to the practice of LAs in a state DOT:

- Licensing and agency guidance.
- Role of landscape architects in the agency.
- Role of consultants.
- Scope of landscape architects' authority and responsibility.

Rhode Island, the seventh state DOT selected to receive the survey, did not respond as the landscape architect vacated the position in the department.

The full text of survey responses for the agencies responding to this survey appear in [Appendix A](#).

## **Summary of Findings**

The six agencies provided a broad range of responses about the roles, responsibilities and authority of LAs practicing in state DOTs. Areas where we found some consensus among the agencies include:

- None of the agencies noted any special requirements for LAs working in transportation.
- All agencies mentioned some type of written policy or guidance that addresses the role or activities of LAs. The type of guidance ranges from statutes and administrative rules to manuals, procedures and position descriptions.
- None of the state DOTs reported areas of inconsistency when comparing the activities of LAs in these agencies with the rules and regulations governing those activities.
- When asked about the division or unit where LAs are working within these agencies, all agencies cited the design division (other divisions or units were also mentioned).
- None of the agencies reported having an LA participate on *all* design and project development teams.
- Practices for signing and sealing documents by in-house LAs are uniform across the districts or regions of the agencies.

The following summarizes other findings in each topic area.

## **Licensing and Agency Guidance**

Half of the agencies require passage of a national exam—the Landscape Architect Registration Examination—for licensing of LAs in the respective states. Licensing is managed through a range of state agencies or boards, and states may have additional requirements, such as education, experience and passage of a state exam, to become a licensed LA.

In addition to statutes and agency policy, Florida, Nevada and New York State DOTs provided or excerpted job descriptions that offer guidance for the LA practice. In New York, the DOT's liaison and training programs support the LA community and provide opportunities to share information about landscape architecture throughout the department.

## **Role of Landscape Architects in the Agency**

The number of LAs working in the agencies we surveyed varied widely, from a low of three in Oregon DOT to a high of 35 in New York State DOT. Texas and Washington State DOTs reported having 15 LAs on staff. Most agencies have LA staff spread across districts or regions and the central office.

The agencies' LAs perform a range of activities. LAs commonly participate, as in New York State DOT, in "all aspects of design for landscape components of transportation projects." At least half of the agencies also have LAs working on projects involving aesthetics, erosion and sediment control, and environmental analysis or mitigation.

While none of the agencies include LAs on *all* project teams, LAs in Florida and New York State DOTs participate on *most* project teams. In Florida, the practice of including LAs on most, if not all, design and project management teams will be reflected in an updated procedure. In Washington, LAs participate on project teams unless the project involves paving with no roadside impacts. LAs in Oregon DOT rarely serve as project managers. The types of projects most likely to be led by an LA are stand-alone landscape-specific projects or environmental mitigation projects.

## **Role of Consultants**

We found no consensus when we asked the agencies to estimate the percentages of LA work performed by in-house LAs and consultants. Florida and Nevada DOTs use consultants for almost all LA work, while Texas and Washington State DOTs retain most LA work in-house. Oregon DOT reports an even split, tending more toward an emphasis on the use of in-house staff. New York State DOT did not provide an estimate given that the allocation of LA work varies considerably across the agency's regions.

All but Washington State DOT specified that consultants working on behalf of the state DOT to prepare a design, plan or specification are responsible for signing and sealing those documents, with the in-house LA responsible for oversight, including plan review and approval. The agencies reported differing practices for quality assurance/quality control, with Oregon and Texas DOTs noting that all deliverables prepared by consultant LAs are reviewed at project milestones.

## **Scope of Landscape Architects' Authority and Responsibility**

Some agencies noted that signing and sealing documents are described in state statutes. In-house LAs in Nevada DOT do not sign and seal in-house designs; rather, all plans are covered under the signature of the department's director. The most commonly cited document types that are signed and sealed by an in-house LA include erosion and sediment control plans, irrigation plans and details, and planting/landscape plans.

When asked about the types of documents that require a CE's signature and seal, the agencies provided examples of projects such as drainage structures, hydraulic plans and mitigation plans.

As might be expected, state statute was noted as a critical factor in determining when project documents are signed and sealed by an LA or CE. Agencies provided examples of project documents that can be signed and sealed by either an LA or CE, such as site plans, grading plans and sidewalk/pedestrian plans; drawings for small walls and structures; and erosion control plans and specifications that can be signed by an LA, CE or registered geologist.

Agencies cited state statute and agency policies as providing guidance in identifying the scope of responsibilities for LAs and CEs. With regard to the possible overlapping of the roles of the LA and CE, in Florida drainage plans can be signed and sealed by LAs or engineers, though the agency continues to rely exclusively on engineers for signing and sealing these documents. In Texas, efforts are made to address potential conflicts early in project development.

## **Gaps in Findings**

Some agencies provided more detailed answers than others, and some questions elicited more detailed responses from agencies. Caltrans may wish to follow up on some responses to gain additional perspective.

Caltrans may also wish to consider how the role of LAs in other state agencies, as presented in this Preliminary Investigation, compares to the activities of Caltrans' LAs. The information gathered for this Preliminary Investigation can inform an internal information-gathering effort.

## **Next Steps**

Moving forward, Caltrans could consider:

- Gathering LA-related position descriptions from state DOTs to inform Caltrans' understanding of how LAs operate within other agencies.
- Examining in greater detail the scope of authority of other states' LAs as defined in state practice acts.
- Surveying Caltrans' LAs to compare the agency's current state of the practice with the practices identified in this Preliminary Investigation.

## Detailed Findings

### Survey Approach

We distributed an email survey to six state DOTs—Florida, Nevada, New York, Oregon, Texas and Washington—that were selected by Caltrans as having experience with landscape architecture. (Rhode Island, the seventh state DOT selected to receive the survey, did not respond as the landscape architect vacated the position in the department.) The survey consisted of the following questions:

#### **Licensing and Agency Guidance**

1. How are transportation landscape architects (TLAs) licensed in your state?
2. Does your agency have written policies or guidance on the role of TLAs in your agency? If yes, please provide a link or an electronic copy of the relevant documentation.
3. Have you identified any areas of inconsistency with regard to the activities permitted by your state's landscape architects practice act, rules and regulations, and the actual practice of TLAs in your agency?

#### **Role of Transportation Landscape Architects in the Agency**

1. How many licensed TLAs does your agency employ, and in which divisions or units are they working?
2. Please describe the types of planning and design activities performed by TLAs within your agency and how these activities differ by functional area.
3. Do TLAs participate on all design or project development teams?
4. For what types of projects do TLAs serve as project managers?

#### **Role of Consultants**

1. What are the percentages of TLA work performed by in-house TLAs and consultants?
2. When your agency uses consultants for TLA work, how do you address oversight, review, approval, and signing and sealing/stamping of drawings, specifications or other instruments of service prepared by the consultant?

#### **Scope of Transportation Landscape Architects' Authority and Responsibility**

1. Please describe the drawings, specifications or other instruments of service a TLA may sign and seal/stamp.
  - a. Is this uniform across all regions or districts?
2. What types of documents prepared for projects that include TLA participation require the signature and seal/stamp of a civil engineer (CE)?
3. Are there project documents that can be signed/sealed by either a TLA or CE? Please describe.
4. How is the scope of authority and responsibility of a TLA different from or similar to, or how does it overlap with, that of a CE within your agency?

5. Has your agency identified areas of conflict with regard to the roles, responsibilities and signing authority of TLAs and CEs working together on transportation projects? If yes, how have you resolved those conflicts?

### **Wrap-Up**

1. Do you have other comments you'd like to offer about an issue related to TLAs in your agency that we haven't addressed?

## **Survey Results**

Survey results are presented below. Responses are organized in four topic areas related to the practice of landscape architecture in a state DOT:

- Licensing and agency guidance.
- Role of landscape architects in the agency.
- Role of consultants.
- Scope of landscape architects' authority and responsibility.

*Note:* Several of the agencies we contacted do not use the term "transportation landscape architect." For this reason, while the survey questions used the term "transportation landscape architect," the discussion of survey results that follows uses "landscape architect" or "LA."

### **Licensing and Agency Guidance**

#### **Licensing Landscape Architects**

We asked how LAs are licensed in each state. While the survey did not specifically address the examinations required for licensing LAs working in transportation, we did identify that all agencies require passage of a national exam—the Landscape Architect Registration Examination (LARE), an exam overseen by the Council of Landscape Architectural Registration Boards—to be eligible for licensure. Agencies also reported other requirements:

- Licensure requirements in New York and Oregon include a combination of education, experience and passing the LARE.
- Oregon may require passage of the LARE and/or an oral examination as determined by the governing board.
- Florida requires passage of the national LARE and a state exam. LAs must be prequalified with FDOT to pursue consultant-related contractual work.

Licensing is done through a range of state agencies or boards, including:

- Department of Business and Professional Regulation.
- State Education Department.
- Board of Architectural Examiners.
- Landscape Architecture Board.

None of the agencies noted any special requirements for LAs working in transportation.

## Related Resources:

**Landscape Architect Registration Examination (L.A.R.E.) Orientation Guide**, Council of Landscape Architectural Registration Boards, August 2013.

<https://www.clarb.org/Candidates/Documents/LAREOrientationGuide.pdf>

This guide provides background on the LARE, which “tests applicants for the knowledge and skill that is required to practice those aspects of landscape architecture that impact the health, safety and welfare of the public.”

**State Licensure Laws**, American Society of Landscape Architects, 2014.

<http://www.asla.org/StateGovtAffairsLicensure.aspx>

Click on a state appearing on the map of the United States to access a summary of the provisions of that state’s landscape architecture licensure laws. Among the issues addressed in each state summary are definitions (the scope of the practice), eligibility requirements, requirements for initial licensure, seal requirements and information about mandatory continuing education.

## Written Policies or Guidance

The types of written policies or guidance associated with the activities of LAs vary, from statutes and administrative rules that govern professional practice to formal agency procedures that address the plan review process. Agencies also reported the use of a landscape and aesthetics master plan, and a landscape and aesthetics design manual that outlines the role of LAs in the design process. New York State DOT’s Highway Design Manual includes a chapter devoted to LAs and community design for transportation.

In Texas, a standard operating procedure for landscape project development has been drafted but is not yet in wide circulation. Florida DOT is working to include LAs in all roadway planning and design processes for both existing and proposed landscapes. These changes in procedure are ascribed to heightened awareness of the value and importance of the natural beauty and scenic attributes of this state. FDOT is also relying on LAs to develop guidance for making stormwater facilities an attractive resource. Job descriptions also illustrate the roles and expectations for LAs at various levels.

New York State DOT’s efforts to provide guidance go beyond written policies, including a robust internal web site and liaison and training programs that support the community of LAs and provide opportunities to share information about landscape architecture throughout the department.

## Comparing Actual Practice with Practice Laws

None of the six agencies we contacted were aware of areas of inconsistency when comparing the activities of LAs with the rules and regulations governing those activities. However, Florida DOT noted that LAs “have done a poor job helping others understand the full scope of the profession’s expertise and experience.”

## Role of Landscape Architects in the Agency

### Licensed Landscape Architects Employed by the Agency

We asked how many licensed LAs are employed by the agencies and in which divisions or units they are working. The table below summarizes responses.

<b>Number of Licensed Landscape Architects on Staff</b>		
<b>State</b>	<b>Number of LAs on Staff</b>	<b>Division/Unit</b>
<b>Florida</b>	6	Design, environmental management, maintenance (across districts and central office). <i>Note:</i> Dozens of consultant LAs are responsible for programs and projects.
<b>Nevada</b>	4	Road design (one supervising LA and three senior LAs). <i>Note:</i> The most recently hired staff person is working at a lower level of responsibility while working on licensure. After licensing, the new staff person will be elevated to a full licensed position.
<b>New York</b>	35	Landscape/environment units in 11 regions; landscape architecture and design services bureaus in main office.
<b>Oregon</b>	3	Design (two in regions; one in central office).
<b>Texas</b>	15	Design (2), environmental (1), regional districts (12).
<b>Washington</b>	15	Design, maintenance, planning, environmental.



## Types of Planning and Design Activities Performed by Landscape Architects

LAs perform a range of activities. The table below summarizes survey responses.

Planning and Design Activities Performed by Landscape Architects	
State	Types of Planning and Design Activities
<b>Florida</b>	<ul style="list-style-type: none"> <li>• Participate in landscape project design and plan implementation during construction.</li> <li>• Head the scenic highway program.</li> </ul>
<b>Nevada</b>	<p>Supervising LA:</p> <ul style="list-style-type: none"> <li>• Oversee implementation of the Landscape and Aesthetic Master Plan (LAMP).</li> <li>• Oversee and update various landscape and aesthetic corridor plans.</li> <li>• Provide direction and guidance to consultant LAs on design concepts/themes.</li> </ul> <p>Senior LA:</p> <ul style="list-style-type: none"> <li>• Coordinate the use of and solicit consultants for LA projects. <ul style="list-style-type: none"> <li>○ Perform plan reviews and inspections.</li> <li>○ Coordinate consultant project design implementation.</li> </ul> </li> <li>• Develop designs and special provisions for landscape and aesthetics projects or elements for transportation projects. <ul style="list-style-type: none"> <li>○ Develop concepts/themes for in-house designs.</li> <li>○ Develop contract plans and specifications for in-house designs.</li> <li>○ Coordinate design implementation.</li> </ul> </li> <li>• Assist in development, revision and implementation of LAMP and corridor plans.</li> </ul>
<b>New York</b>	<ul style="list-style-type: none"> <li>• Engage in all aspects of design for landscape components of transportation projects.</li> <li>• Engage in traditional design, planning, environmental review and field work, construction, maintenance and supervision at all levels and administration.</li> <li>• Specific activities include scoping, site inventory and analysis, planting and hardscape design, drafting, grading, specifications, GIS, erosion and sediment control, landscape protection, site planning, community outreach, interagency coordination, aesthetics, environmental analysis, visual impact assessment, construction support, bike/pedestrian design and consultant management.</li> </ul>

## Planning and Design Activities Performed by Landscape Architects

State	Types of Planning and Design Activities
<b>Oregon</b>	<ul style="list-style-type: none"> <li>• Provide guidance on and produce plans, specifications and estimates for roadside development and erosion and sediment control. (LAs are used on more complex erosion control projects.)</li> <li>• Work in concert with staff engineers as members of project teams for projects involving revegetation, hardscape development and visual resource analysis (architectural treatments on structures).</li> <li>• Work with and provide comment on the work of consultant LAs.</li> <li>• Work closely with the Environmental Services team on mitigation projects.</li> <li>• In the central office, set the statewide policy and program for roadside development while working closely with regional LAs.</li> </ul>
<b>Texas</b>	<ul style="list-style-type: none"> <li>• Planting design, site/facility planning and design primarily focused on structural aesthetics, roadside landscape, erosion control and vegetation establishment.</li> </ul> <p><i>Note:</i> Roles tend to differ by district. LAs in some of the smaller districts are limited to maintenance of roadside vegetation and landscapes around office buildings. LAs in larger urban districts are typically involved in roadside and structural aesthetics, environmental projects and enhancement designs.</p>
<b>Washington</b>	<ul style="list-style-type: none"> <li>• Develop roadside policy, environmental mitigation plans, and project design and implementation.</li> <li>• Coordinate plant establishment work to meet permit requirements.</li> <li>• Write specifications for roadside and erosion control materials, and serve as the subject matter experts for materials approvals for these items (for example, compost, hydromulches, seeding and erosion control blankets).</li> </ul>

### Extent of Landscape Architect Participation on Project Teams

None of the agencies indicated that LAs participate on *all* design or project development teams, though Florida and New York State DOTs indicated that LAs participate on *most* project teams. In Florida, this practice is currently being codified in procedures to include LAs in most, if not all, project teams. In New York, there is a long history of integrating LAs into project teams at all levels within NYSDOT, with many LAs participating on teams as high-level managers.

The presence or lack of roadside impacts determines LA involvement on project teams in Nevada, Oregon and Washington, with Washington State DOT LAs participating on all projects other than paving projects with no roadside impacts. In Oregon, LAs participate in only those projects involving roadside development and on the more complicated projects that include erosion control. In Nevada, LAs do not participate in pavement rehabilitation projects unless slope work is involved.

Nevada DOT provided examples of the types of projects that include LA participation:

- Capacity and widening projects.
- New construction.
- Bridge replacements.
- Roundabouts.
- Stand-alone landscape and aesthetic projects.

Nevada DOT also identified the types of projects that *do not* involve LA participation:

- Safety projects (unless construction of roundabouts or shoulder widening/flattening).
- Maintenance projects such as chip seals, slurry seals or cold mix overlays.

### **Landscape Architects Serving as Project Managers**

LAs rarely serve as project managers for Oregon DOT. LAs in Nevada, New York State and Washington State DOTs serve as project managers for stand-alone landscape-specific projects or environmental mitigation projects. Agencies provided examples of the types of projects led by an LA, including:

- Irrigation system design and construction.
- Landscape development and enhancement.
- Pedestrian facility design.
- Stand-alone roadside restoration, environmental mitigation, and landscape and aesthetic projects, including:
  - Planting.
  - Sidewalk/streetscape projects.
  - Restoration of park facilities (if used as staging for other construction).
  - Bicycle and greenway facilities.
  - Wetland mitigation.
  - Multisite minor landscape maintenance/asset preservation projects.

### **Role of Consultants**

#### **Work Performed by In-House and Consultant Landscape Architects**

We found no consensus when we asked the agencies to estimate the percentages of LA work performed by in-house LAs and consultants. Florida and Nevada DOTs use consultants for almost all LA work, while Texas and Washington State DOTs retain most LA work in-house. Oregon DOT reports an even split, tending more toward an emphasis on in-house staff, and New York State DOT did not provide estimates given that allocation of LA work varies considerably across the agency's regions.

The table below summarizes responses.

Percentage of Work Completed by In-House and Consultant Landscape Architects			
State	Percentage of Work Completed by In House LAs	Percentage of Work Completed by Consultant LAs	Comments
Florida	5%	95%	Half of the agency's district LAs are in-house consultants.
Nevada	10%	90%	None.
New York	Varies	Varies	Varies across regions and with the scale and type of projects; all regions have in-house capabilities and regularly perform design.  Large urban areas have more complex projects often requiring environmental assessments or impact statements; these large construction teams typically include consulting LAs.
Oregon	50%	50%	Moving closer to 75% of LA work being done by in-house staff.
Texas	90%	10%	In-house staff performs most of the work on projects located on state right of way using state funds.  Consultants perform almost all of the work on projects not located on state right of way.
Washington	80%	20%	Consultants are used more on design-build megaprojects.

### Oversight of Consultant Work

All but Washington State DOT reported that consultants working on behalf of the state agency to prepare a design, plan or specification are responsible for signing and sealing those documents, with the in-house LA responsible for oversight, including plan review and approval. (Washington State DOT's survey response did not address signing and sealing.) For New York State DOT, the regional director overseeing the project also signs a project document's title page as a representative of the agency's commissioner for the project as a whole. Other issues related to consultant oversight include:

- *Project participation.* Oregon DOT noted that a consultant LA will participate on agency design teams that may also include an in-house LA.
- *Quality assurance/quality control.* Responsibility for quality assurance/quality control differs, with Nevada DOT noting that it is the responsibility of the consultant, while state

contracts in New York require a quality assurance/quality control review by the assigned project manager.

- *Specifications.* In Nevada, while the consultant provides suggested language and requirements for specifications, Nevada DOT's specification section develops the actual language.
- *Deliverable review.* Oregon and Texas DOTs noted that all deliverables are reviewed at project milestones (in Oregon, this is preliminary, advance and final), and feedback is provided.
- *Challenges.* Design-build projects present more challenges for Washington State DOT when conducting consultant oversight. Contract specifications and the firms involved affect the level of difficulty in conducting oversight on these projects.

## **Scope of Landscape Architects' Authority and Responsibility**

### **Project Documents Signed and Sealed by In-House Landscape Architects**

Agencies offered a range of responses to a question about the types of documents or instruments of service signed and sealed by in-house LAs; however, all agencies said that practices are uniform across districts or regions.

Only Nevada DOT indicated that in-house LAs do not stamp in-house designs (plans, specifications or estimates). For this agency, all plans are covered under the signature of the department's director. However, Nevada DOT does require that consultant LAs stamp their design plans. NDOT generates the actual specifications on consultant designs based on input and notes provided by the consultants, but does not require the consultant to stamp the specification notes or cost estimate.

Some agencies provided a list of the types of documents signed and sealed by LAs, while others offered a more general response (for example, that signing and sealing documents are described in state statutes). In New York, the practice of signing and sealing documents is a judgment call on a project-by-project basis and is guided by the scope of the practice defined in state statute and agency policy.

The following examples of the types of documents signed and sealed by in-house LAs were provided by multiple agencies:

- Erosion and sediment control plans (New York and Washington).
- Irrigation plans and details (Florida, Texas and Washington).
- Planting/landscape plans (Florida, New York, Oregon, Texas and Washington).

Only one agency specifically identified each of the following types of plans or projects for which documents are signed and sealed by in-house LAs:

- Aesthetic treatments (New York).
- Construction detail sheets, where appropriate (Texas).
- Contour grading plans (Washington).
- Habitat structures (Washington).
- Project specifications (Texas).

- Site designs and details (New York).
- Stormwater best management practices (Washington).
- Technical special provisions (Florida).
- Visual impact analyses (New York).

In Florida, hardscape drainage plans, stormwater management plans and permitting documents are very rarely signed and sealed by in-house LAs.

### **Project Documents Requiring the Signature and Seal of a Civil Engineer**

When asked about the types of plans that require the signature and seal or stamp of a CE, Florida DOT provided this succinct reply: any plan other than a landscape or irrigation plan. (Other survey responses indicate that the scope of authority and responsibility of LAs in FDOT is limited.) For New York State DOT, the vast majority of projects and documents, including those with components that are signed and sealed by an LA, require a CE's seal and signature.

In Nevada, while projects related to erosion control, revegetation methods and drainage are sometimes within the scope of both a CE and LA working jointly on such projects, the CE will ultimately have authority over the hydraulic design.

Other agencies provided examples of the types of projects that generate documents signed and sealed by a CE (these projects might also include work completed by an LA):

- Hydraulic plans and reports and in-channel work (Nevada and Washington).
- Major drainage structures (Texas).
- Mitigation plans (Florida).
- Roadways, including bike and pedestrian facilities (Florida, Nevada and Washington).
  - Roadway lighting (Florida).
  - Signage and pavement marking (Florida).
- Sound walls (Florida).
- Stormwater management permit applications to state and federal agencies (Florida).
- Structural retaining walls (Texas).
- Structures/architectural treatments on structures (Florida, Nevada and Oregon).
- Traffic control plans (Texas).
- Utilities (Florida).

## **Project Documents Signed and Sealed by a Landscape Architect or a Civil Engineer**

As might be expected, state statute is a critical factor in determining when project documents are signed and sealed by an LA or CE.

- While state statutes provide broad authority for Florida DOT's LAs to sign and seal project documents, FDOT applies a narrow reading of the statute. In practice, FDOT limits the scope of LAs' document signing and sealing to landscape plans and irrigation plans. All other plans are signed and sealed by the engineer of record.
- In Nevada, there is some overlap in the types of documents an LA and CE can sign and seal as dictated by state law. While some elements of a landscape design can be stamped by a registered LA, any elements that are part of the landscape design that cannot be stamped by the LA (such as foundations for sculptural elements) are stamped by a CE.

Other examples of project documents that can be signed and sealed by either an LA or CE:

- Site plans, grading plans, sidewalk/pedestrian plans and stream channel plans.
- Drawings for small walls and structures (such as kiosks or decks) may fall under the scope of an LA and could also be signed and sealed by a CE.
- Erosion control plans and specifications can be signed by an LA, CE or registered geologist.

## **Scope of Responsibilities for Landscape Architects and Civil Engineers**

Nevada DOT noted that the authority and responsibility for an LA are similar to a CE. However, there are phases of work where the CE has a higher level of responsibility or authority. This generally occurs in the construction phase. The resident engineer in charge of overseeing the construction of the contract has final say on both LA and CE elements.

Below are examples of agency practice and guidelines determining the scope of responsibilities:

- Agency recognition of each professional's area of expertise determines the scope of responsibilities. For example, Florida DOT applies a narrow reading of the scope of responsibilities as dictated by statute.
- Stamping authority policies provide clear guidance as to the scope of responsibilities of each type of professional.
- LAs have authority and responsibility across the regions to fulfill any state-mandated requirements controlled by licensure.

In New York, LAs are exclusively responsible for activities such as planting, aesthetics, the layout of landscape features, visual impact assessments and context-sensitive material selection. Many general administrative and supervisory responsibilities can be filled by an LA, CE or Environmental Specialist. Such responsibilities include managing a squad, planning activities, public outreach, drafting of guidance documents, GIS analysis, consultant management and local project administration.

Perception of the scope of responsibilities differs in Texas DOT. The central office view is that authority and responsibility are similar when projects fall into the respective areas of responsibility. Instances where responsibilities overlap are handled on a project-by-project basis. In contrast, one of the TxDOT districts notes that CE authority overrides that of an LA.

### **Areas of Conflict**

Most agencies reported no conflicts with regard to the possible overlapping of the roles of the LA and CE, or indicated efforts to address potential conflicts early in project development. Agencies offered this advice:

- Offer recommendations rather than open the door to potential conflict. For example, recommend different methods to achieve erosion control or drainage requirements by offering suggestions for meeting these requirements in a more attractive manner than can be achieved under an initial proposal.
- Maintain good working relationships, mutual respect, clear communication and a clear policy about roles and responsibilities. These practices are effective in working with representatives from any discipline.
- In areas where signing authority can be conflicting, establish early in project development what those responsibilities will be.

In Florida, the only area of conflict relates to drainage plans. Though state statute allows either licensed professional (LA or CE) to sign and seal, FDOT continues to rely exclusively on CEs.



## Appendix A: Full Survey Responses

The full text of each survey response is provided below. Responses are organized in the following topic areas by question and then by the state DOT providing the response.

- Licensing and agency guidance.
- Role of transportation landscape architects in your agency.
- Role of consultants.
- Scope of transportation landscape architects' authority and responsibility.
- Wrap-up.

Related resources are included where relevant.

*Note:* We received two responses from Texas DOT: one response from the central office and a second response from a Texas DOT district. Where appropriate, the use below of “(Central Office)” and “(District)” identifies the responses.

### Licensing and Agency Guidance

#### 1. How are transportation landscape architects (TLAs) licensed in your state?

**(Florida)** All LAs in the state of Florida are licensed through the State of Florida Department of Business and Professional Regulation by passing a state exam and the national [Landscape Architect Registration Examination]. Landscape architects must become prequalified with FDOT in order to pursue contractual work. No specific requirements for transportation.

**(Nevada)** At NDOT the landscape architects are not referred to as transportation landscape architects. Nevada licensure does not have any separate designation such as “transportation landscape architects.” They follow the normal process for LA licensure.

**(New York)** Landscape architecture is a licensed profession in New York State, with no unique qualifications or extra steps for LAs working in transportation. Licensure is granted by the New York State Education Department, whose web site spells out the licensure requirements [see Related Resource below], which are a combination of education, experience and passing the [Landscape Architect Registration Examination] administered by the Council of Landscape Architectural Registration Boards.

Related Resource:

**License Requirements: Landscape Architecture**, Office of the Professions, New York State Education Department, April 7, 2014.

<http://www.op.nysed.gov/prof/larch/larchlic.htm>

This web site describes the requirements to practice landscape architecture in the state of New York.

**(Oregon)** Oregon statutes provide for licensing requirements and the setting up of the Oregon Landscape Architect Board [see Related Resource below].

Related Resource:

**Oregon Landscape Architect Board**, State of Oregon, undated.

<http://www.oregon.gov/LANDARCH/Pages/index.aspx>

The board's mission is to "regulate (which is to govern or direct according to rule) the practice of landscape architecture in Oregon."

**(Texas)** Landscape architects are licensed through the Texas Board of Architectural Examiners. No specialization exists.

**(Washington)** We are licensed the same as all landscape architects, using the CLARB test. [CLARB is the acronym for the Council of Landscape Architectural Registration Boards. The exam the respondent is referring to is the Landscape Architect Registration Examination (LARE).]

**2. Does your agency have written policies or guidance on the role of TLAs in your agency? If yes, please provide a link or an electronic copy of the relevant documentation.**

**(Florida)** The Highway Landscape, Beautification and Plan Review Procedure [see Related Resources below] has the best description of the role of the department's district landscape architects. Each district has a variation of this. The central office has a single position for the State Transportation Landscape Architect. A position description is attached [see Related Resources below].

Related Resources:

**Highway Landscape, Beautification and Plan Review**, Topic No.: 650-050-001-e, Florida Department of Transportation, December 2, 2003.

See [Appendix B](#).

*From the document:* Purpose: To provide for the conservation of natural roadside growth and scenery and for the implementation and maintenance of roadside beautification programs. To provide safe, aesthetic, environmentally sound, cost effective, and manageable roadways. To establish a uniform statewide process for review of landscape plans, and for administration of the Florida Highway Beautification Council Grant Program.

**Position Description**, Current Class Title: Landscape Architect, State of Florida, undated.

See [Appendix C](#).

This position description provides the duties and responsibilities of a landscape architect currently employed by FDOT (one of the survey respondents).

**(Nevada)** We don't have written policies or guidance on the role of TLAs but we do have written policies/guidance on landscape and aesthetics, the Landscape and Aesthetic Master

Plan (LAMP) and various corridor studies that provide further guidance on specific routes in the state [see Related Resources below].

#### Related Resources:

**Aesthetic Alternatives for NDOT Design Standards**, Design Workshop, Nevada Department of Transportation, December 22, 2009.

[http://www.nevadadot.com/uploadedFiles/NDOT/About\\_NDOT/NDOT\\_Divisions/Engineering/Design/Landscape/Aesthetic-Alternatives.pdf](http://www.nevadadot.com/uploadedFiles/NDOT/About_NDOT/NDOT_Divisions/Engineering/Design/Landscape/Aesthetic-Alternatives.pdf)

*From the document:* This document contains a library of aesthetic alternatives to existing Nevada Department of Transportation (NDOT) practices. If followed, these alternatives will help NDOT pursue a holistic approach to landscape and aesthetics on Nevada's highways. Beautiful, site appropriate highways contribute to Nevada's tourism-based economy as well as to the quality of life of its growing population.

**Pattern and Palette of Place: A Landscape and Aesthetics Master Plan for the Nevada State Highway System**, Nevada Department of Transportation, July 3, 2002.

[https://www.nevadadot.com/uploadedFiles/NDOT/Projects\\_and\\_Programs/Landscape\\_and\\_Aesthetics/LandA\\_MasterPlan-July3.pdf](https://www.nevadadot.com/uploadedFiles/NDOT/Projects_and_Programs/Landscape_and_Aesthetics/LandA_MasterPlan-July3.pdf)

*From the plan:* The goal of this *Master Plan* is to establish a landscape and aesthetics program for the Nevada state highway system. The program will provide a vehicle for NDOT and Nevada's communities to improve the quality of life in the state by allowing us to beautify highways, improve the state's public image, welcome visitors, and contribute to a tourist-based economy. With careful attention, the landscape and aesthetics program can create highways that celebrate the state's many beautiful landscapes, as well as its diverse populations.

**Landscape and Aesthetics**, Nevada Department of Transportation, 2014.

[http://www.nevadadot.com/About\\_NDOT/NDOT\\_Divisions/Engineering/Design/Landscape/Landscape\\_and\\_Aesthetics.aspx](http://www.nevadadot.com/About_NDOT/NDOT_Divisions/Engineering/Design/Landscape/Landscape_and_Aesthetics.aspx)

This web site provides links to corridor plans that provide landscape-specific guidance on routes on several corridors in the state.

**(New York)** Though there is no single written policy or guidance document for the department on the role of landscape architects, LAs entering or being promoted within NYSDOT will have responded to a posting including a job description. New York State Civil Service maintains a class series for landscape architecture [see Related Resources below], describing the roles and expectations for landscape architects at various levels from Junior through Principal.

Once on staff, a landscape architect's specific duties are worked out with their supervisors via annual work programs and performance evaluations. LAs are situated in program areas throughout NYSDOT serving in a vast and varied range of roles, from traditional design to planning, environmental review and field work, construction, maintenance, supervision at all levels and administration. The Landscape Architecture Bureau maintains a robust internal web site and conducts liaison and training programs both to support the community of LAs and to share information about landscape architecture throughout the department.

Related Resources:

**Landscape Architect Class Series**, Classification Specification, New York State Department of Civil Service, November 1997.

[http://www.cs.ny.gov/tsplan/tsp\\_display2.cfm?specCode=5001100F](http://www.cs.ny.gov/tsplan/tsp_display2.cfm?specCode=5001100F)

*Brief description of class series:* Landscape Architects perform professional activities, requiring specialized training and experience, to plan and design landscape development and site improvement projects, select materials, estimate costs, prepare environmental analysis and reports, and supervise the construction and maintenance of the landscape for transportation facilities, buildings, parks, historic sites, and other facilities. Aesthetics, the architectural and natural environment, environmental impact, and the multiple functions and uses of facilities are significant factors in their work. Most positions in this series are in the Department of Transportation, the Office of General Services, and the Office of Parks, Recreation and Historic Preservation.

**Landscape Architects and NYSDOT's Project Development Process**, New York State Department of Transportation, April 2009.

See [Appendix D](#).

This presentation was delivered at training sessions to a broad cross-section of department staff. Objectives included:

- Understand what landscape architecture is.
- Recognize what the LA license covers—how it affects the health, safety and welfare of the public.
- Comprehend the legal basis for the work performed by LAs on transportation projects.
- Understand the value LAs add throughout the project development process to help our projects meet the stated goals and objectives of the department.

**(Oregon)** ODOT follows the Oregon statutes and administrative rules governing the practices of several professions, including engineers, surveyors, photogrammetrists, geologists and engineering geologists, and landscape architects. These documents describe the kinds of work done by the various professions, and ODOT has determined that landscape architects typically work on roadside development and erosion control design. However, some work like erosion control can be done by other professions as well, so we tend to use licensed landscape architects on the more complex and difficult projects. Landscape architects are also sometimes used to provide recommendations for visual resources, and this can include architectural treatments on structures.

**(Texas)** Yes. The Landscape Section of the Design Division of TxDOT maintains a Landscape and Aesthetics Design Manual, which outlines the role of Landscape Architects in the design process [see Related Resource below]. There is a draft Standard Operating Procedure for Landscape Project Development, but it has not been widely circulated yet.

Related Resource:

**Landscape and Aesthetics Design Manual**, Texas Department of Transportation, October 2012.

<http://onlinemanuals.txdot.gov/txdotmanuals/lad/lad.pdf>

Issues covered in this design manual include assessment, planning and design; the project development process; landscape and aesthetics guidelines for common

structural elements; and landscape and aesthetics guidelines for common transportation system features.

**(Washington)** Yes.

Related Resource:

**Certification of Documents by Licensed Professionals**, Secretary's Executive Order Number E 1010.01, Washington State Department of Transportation, February 16, 2012. See [Appendix E](#).

This document includes a reference to the Washington statute governing landscape architects.

**3. Have you identified any areas of inconsistency with regard to the activities permitted by your state's landscape architects practice act, rules and regulations, and the actual practice of TLAs in your agency?**

**(Florida)** Nearly all work for TLAs in Florida is limited to preparing landscape plans and assisting with implementation of the plan during construction. There are few opportunities for landscape architects to be involved with other planning and design responsibilities. Landscape architects have done a poor job helping others understand the full scope of the profession's expertise and experience.

**(Nevada)** All the activities landscape architects perform at NDOT fall within the license laws for Nevada.

**(New York)** None. The work of LAs in NYSDOT is consistent with the description of the profession as described in NYS Education Law §7321 [see Related Resource below].

Related Resource:

**Definition of Practice of Landscape Architecture**, Section 7321, Title 8, The Professions, Article 148, New York State Codes, undated.  
<http://www.socratek.com/StateLaws.aspx?id=1126122&title=7321%20Definition%20Of%20Practice%20Of%20Landscape%20Architecture>

This state code defines the practice of landscape architecture in New York.

**(Oregon)** No.

**(Texas)** No.

**(Washington)** No inconsistencies have been brought to my attention.

## **Role of Transportation Landscape Architects in Your Agency**

### **1. How many licensed TLAs does your agency employ, and in which divisions or units are they working?**

**(Florida)** Six (6) that are actual FDOT employees. They are working in Office of Design, Environmental Management, and Maintenance in districts and the central office. Dozens of consultant landscape architects are responsible for programs and projects.

**(Nevada)** Currently, the department has 3 licensed TLAs, but we've recently added a 4th position but had to underfill (employed at a lower skill level at a lower pay) it with someone working on their licensure. Once they obtain their license they will be elevated to the full licensed position and the pay adjusted accordingly.

All four landscape architects are located within the Road Design Division of the department.

1 – Supervising Landscape Architect

3 – Senior Landscape Architects (one will be underfilled)

**(New York)** Once again, we do not use the term “TLA” in NYSDOT. NYSDOT has approximately 35 licensed landscape architects distributed primarily among the landscape/environmental units of its 11 regions, plus the main office Landscape Architecture Bureau and Design Services Bureau.

**(Oregon)** ODOT has three landscape architects, two in regional design offices and one in the headquarters office.

**(Texas)** 15. Design Division (2), Environmental Division (1), Regional Districts (12).

**(Washington)** About 15 in Design, Maintenance, Planning, and our Northwest region Environmental office.

### **2. Please describe the types of planning and design activities performed by TLAs within your agency and how these activities differ by functional area.**

**(Florida)** Florida TLAs perform activities related to landscape project design and construction. Two of the department's landscape architects lead the scenic highway program.

#### **(Nevada)**

Supervising Landscape Architect

1. Oversees the LAMP implementation.
2. Oversees and updates the various Landscape and Aesthetic Corridor Plans.
3. Provides direction and guidance to consultant LAs on the development of design concepts/themes and the plans.

Senior Landscape Architect

1. Coordinate use of and solicit architectural and engineering firms for the design and engineering of Landscape & Aesthetics (L&A) projects or L&A portions thereof.

- A. Provides direction and guidance to consultant LAs on the development of design concepts/themes.
  - B. Perform plan reviews and inspections to ensure conformance with NDOT Landscape and Aesthetic Master Plan requirements and policies, L&A Corridor Plans, agency needs and applicable local, state and Federal code and planning requirements are met.
  - C. Coordinate consultant project design implementation with internal and external personnel, local agencies, stakeholders, and interested citizens during project development and completion.
2. Develop designs and special provisions for landscape and aesthetics projects or elements for transportation projects.
    - A. Develop concepts/themes for “in-house” designs.
    - B. Develop contract plans and specifications for “in-house” designs.
    - C. Coordinate design implementation with internal and external personnel, local agencies, stakeholders, and interested citizens during project development and completion.
    - D. Facilitate public input meetings for collecting citizen input.
  3. Assist in the development, revision and implementation of the LAMP and Corridor Plans.

**(New York)** LAs perform all aspects of design for landscape components of transportation projects at all scales. Activities include scoping, site inventory and analysis, planting and “hardscape” design, drafting, grading, specifications, GIS, erosion and sediment control, landscape protection, site planning, community outreach, interagency coordination, aesthetics, environmental analysis, visual impact assessment, construction support, bike/ped design, consultant management. The “mix” of activities depends on the needs of the functional area, but most landscape architects wear many “hats”—if not simultaneously, then over the course of time even if they stay within one area. Over the course of a NYSDOT LA’s career, they will likely move among units and even regions as needs and opportunities allow.

We have a full chapter of our Highway Design Manual devoted to Landscape Architecture and Community Design for Transportation (Chapter 28) [see Related Resource below] to be used and referred to by all in the department. Much is already developed, though some sections on community design and aesthetics are still in process.

Related Resource:

**Chapter 28, Landscape Architecture and Community Design for Transportation,** Highway Design Manual, New York State Department of Transportation, February 20, 2013.

<https://www.dot.ny.gov/divisions/engineering/design/dqab/hdm/chapter-28>

*From the chapter’s introduction:* The purpose of this chapter is to provide guidance on how:

- To determine the visual, physical and cultural resources particular to a community
- Those resources will influence and be integrated into the department’s projects and operational procedure(s).

**(Oregon)** The two LAs in the regional offices work in concert with the ODOT engineers as members of project teams, providing technical expertise and advice on projects involving revegetation, hardscape development and visual resource analysis. They provide guidance on and produce plans, specs, and estimates for roadside development and erosion/sediment control. They also work with and provide comment on the work of non-ODOT LAs who may be on contract to provide LA services as needed. They also work closely with the ODOT Environmental Services team on mitigation projects. The LA in the headquarters office works to set the statewide policy and program for roadside development at ODOT while working closely with the regional LAs.

**(Texas)** (Central Office) Planting design, roadway/bridge aesthetics, site/facility planning and design. (District) Planning and design primarily focus on structural aesthetics, roadside landscape, erosion control and vegetation establishment.

**(Washington)** We work on developing roadside policy, environmental mitigation plans and project design and implementation. We coordinate plant establishment work to meet permit requirements. LAs write specifications for roadside and erosion control materials and serve as the subject matter experts for materials approvals for these items (for example, compost, hydromulches, seeding, erosion control blankets).

### 3. Do TLAs participate on all design or project development teams?

**(Florida)** No. FDOT is currently modifying routine procedures to include TLA's on most if not all design and project management teams.

**(Nevada)** They participate in the following types of projects:

- Capacity projects.
- Widening projects.
- New construction.
- Bridge replacements.
- Roundabouts.
- Stand-alone [landscape and aesthetics] projects.

They generally do not participate in other types of projects:

- Pavement rehabilitation projects unless there is slope work involved, in which case they may be involved in the development of revegetation plans.
- Safety projects unless they involve the construction of roundabouts or shoulder widening/slope flattening, in which case they may be involved in the development of revegetation plans. Or they may be asked to help mitigate slope cuts to soften the visual impact of those cuts.
- Maintenance-type projects such as chip seals, slurry seals, cold mix overlays, etc.

**(New York)** They participate on the vast majority of such teams, as appropriate to the needs. Some teams purely concern civil or structural engineering considerations. The department main office and regions have a long history of integrating LAs into teams at all levels and many LAs are on teams by virtue of their status as high-level managers.



**(Oregon)** Typically, only on projects that involve roadside development, and the more complicated projects that include erosion control.

**(Texas)** No.

**(Washington)** Yes, unless it is a paving project with no roadside impacts, LAs are involved.

#### **4. For what types of projects do TLAs serve as project managers?**

**(Florida)** The TLAs serve as [project managers] on landscape/irrigation projects almost exclusively.

**(Nevada)** (1) They serve as the project managers for the L&A portion of projects. They have the responsibility of overseeing that discipline of the project and coordinating those efforts with the rest of the team. (2) They serve as the project manager for stand-alone L&A projects. They are responsible for the complete project coordination on those projects.

**(New York)** LAs manage “stand-alone” landscape projects such as planting, sidewalk/streetscape projects, restoration of park facilities (if used as staging for other construction), bicycle and greenway facilities, wetland mitigation, multi-site minor landscape “maintenance”/asset preservation projects.

**(Oregon)** At this point, LAs rarely serve as project managers; however, in accordance with ORS 671, it would be “those in which professional services have the dominant purpose of landscape preservation, development and enhancement, including but not limited to reconnaissance, research, planning, landscape and site design.”

**(Texas)** (Central Office) Pedestrian facility design, landscape development, irrigation system design and construction. (District) Landscape development and enhancement projects.

**(Washington)** In our Northwest Region, LAs are project managers for stand-alone roadside restoration or environmental mitigation projects. Other regions do not have the staff to manage a project. We generally serve as consultants or specialty services providers.

## **Role of Consultants**

### **1. What are the percentages of TLA work performed by in-house TLAs and consultants?**

**(Florida)** Half of FDOT’s 8 district landscape architects are in-house consultants. The majority (95%) of the LA design work is performed by contracted consultants.

**(Nevada)** The majority of the design work is completed by consultants (approximately 90%). The remaining design work is done with in-house staff.

**(New York)** This varies considerably across the regions and with the scale and type of projects. The percentages would be time-consuming and difficult to quantify. All regions have in-house capabilities and perform design regularly. Regions with large urban areas typically have larger, more complex projects, often requiring environmental assessments or impact statements, typically with large multifaceted construction teams including consulting landscape architects. Those regions, however, would still be working on in-house projects. The basis for calculating would also depend on whether one means the number of projects, number of hours worked, dollar value of work performed.

**(Oregon)** Currently in Region 2, the balance is about 50/50 and moving closer to 75% being done by in-house staff.

**(Texas)** (Central Office) In-house TLAs—90%, Consultants—10%. (District) For projects located on state right of way using state funds, in-house TLAs perform 95% of the work in the Houston District. For projects not located on state right of way, consultants perform 99% of the work.

**(Washington)** In-house TLAs—80%, Consultants—20%. Outside consultants are used more on the megaprojects in Seattle that are design-build projects.

**2. When your agency uses consultants for TLA work, how do you address oversight, review, approval, and signing and sealing/stamping of drawings, specifications or other instruments of service prepared by the consultant?**

**(Florida)** Oversight is done by the district landscape architect. By executing the contractual agreement for professional services with FDOT the consultant is entirely responsible for the design, accuracy, completeness, quality, and signing and sealing of documents.

**(Nevada)** The NDOT landscape architect has oversight, reviews plans and approves plans and specifications prepared by the consultant. The consultant is the landscape architect of record and will stamp and sign final documents. The consultant is also responsible for QA/QC [quality assurance/quality control] of their documents. Specifications are generated by NDOT through its Specification Section. The consultant provides suggested language and requirements and the Specification Section develops the actual language.

**(New York)** The use of consultants for LA work is the same as for PE [professional engineer] or other professional work—all contracts require quality control and quality assurance by review by the assigned project manager and within the supervisory chain of command of which he/she is a part, as well as by coordination with others in the project team. All final contract documents must bear the seal and signature of a responsible design professional. LAs typically sign and seal the sheets they have prepared, with the Regional Director for the region within which the project is being let (or another high-level PE) signing the title page as a representative of the Commissioner for the project as a whole. We also administer many locally let projects, typically using federal funds, for which the local project sponsor is responsible for assuring that the department's requirements for professional signing/sealing of documents are fulfilled.

**(Oregon)** The consultants participate with ODOT design teams (including ODOT LAs) throughout the project development process, receiving direction and feedback at project milestones (preliminary, advance and final). The consultants provide their professional seal/stamp for this work.

**(Texas)** (Central Office) All deliverables are reviewed at several milestone dates. Work is reviewed for accuracy and appropriateness of design. (District) For projects located on state right of way, the district TLAs review and approve the consultant's work. The consultants seal their own drawings.

**(Washington)** WSDOT LAs oversee LA consultant work as much as possible. Some design-build projects are harder to have input into, depending on the contract specifications and the firms involved.

## **Scope of Transportation Landscape Architects' Authority and Responsibility**

### **1. Please describe the drawings, specifications or other instruments of service a TLA may sign and seal/stamp.**

**(Florida)** Landscape, irrigation, hardscape drainage (very rare) and technical special provisions. (By FL statute, TLAs may sign and seal stormwater management plans and permitting documents, although this is rare if not nonexistent in FDOT as the drainage engineers perform this service.)

**(Nevada)** The NDOT landscape architect is not required to stamp or sign work provided to the department. All plans are covered under the signature of the department's Director.

*Response after requesting clarification:* NDOT landscape architects do not stamp in-house designs (plans, specifications or estimates). However, we do require that consultant landscape architects do stamp their design plans. The department generates the actual specifications on consultant designs, based on input and notes provided by the consultants. We don't require the consultant to stamp their specification notes or cost estimate.

**(New York)** The department follows its Policy on Professional Seals and signature (Engineering Instruction 08-001) [see Related Resource below] to make this judgment call project by project. Landscape Architects may sign any design or construction documents consistent with the scope of the practice of the profession as defined by the state (see answer above on licensure). Landscape architects may sign planting plans, erosion and sediment control plans, site designs and details, aesthetic treatments, etc. plus appropriate environmental analysis such as visual impact analyses.

Related Resource:

**Policy on Professional Seals and Signatures**, Engineering Instruction 08-001, New York State Department of Transportation, January 11, 2008.

[https://www.dot.ny.gov/portal/pls/portal/mexis\\_app.pa\\_ei\\_eb\\_admin\\_app.show\\_pdf?id=6812](https://www.dot.ny.gov/portal/pls/portal/mexis_app.pa_ei_eb_admin_app.show_pdf?id=6812)

*From the document:* PURPOSE: The purpose of this Engineering Instruction is to provide direction on the use of professional seals and signatures on final design reports and construction plans produced by or for the Department consistent with the State Education Law requirements. This policy for professional seals is intended to:

- Identify documents which should be sealed and signed.
- Assure that changes to projects are accomplished in accordance with the New York State Education Law requirements.
- Improve quality, communication, and cooperation between team members.

**(Oregon)** The types of documents that may be stamped are described in statute as follows, and also in the ODOT policy attached [see Related Resource below]:

### **Landscape Architects**

#### **ORS 671.379 Stamps.**

(1) A registered landscape architect shall obtain a stamp of a design authorized by the State Landscape Architect Board. The stamp must bear the name, registration date and registration certificate number of the landscape architect and the legend “registered landscape architect.”

(2) A registered landscape architect shall stamp and sign all final drafts of professional documents that the landscape architect issues for obtaining permits, obtaining approvals by agencies other than the board or fulfilling contractual obligations, including maps, plans, designs, contract documents and reports.”

Related Resource:

**Documents Requiring the Seal of Licensed Engineers, Land Surveyors, Geologists, Landscape Architects, and Photogrammetrists**, TSB11-02(D), Technical Services Directive, Oregon Department of Transportation, August 1, 2011.

See [Appendix F](#).

This document includes a discussion of the use of direction from another professional of record when signing and sealing project documents.

**(Texas)** (Central Office) Planting plans, irrigation system plans, construction detail sheets where appropriate, project specifications, general notes and estimates for landscape development projects. (District) Any drawings which meet the criteria for an LA scope of work per the state licensing board. Traffic control plans for roadside landscape work must be signed by a [civil engineer].

**(Washington)** Contour grading, planting, [temporary erosion and sediment control] (when qualified), stormwater [best management practices], habitat structures, irrigation plans and details.

**1a. Is this uniform across all regions or districts?**

**(Florida)** Yes.

**(Nevada)** Yes.

**(New York)** Yes.

**(Oregon)** Yes.

**(Texas)** Yes.

**(Washington)** Yes.

**2. What types of documents prepared for projects that include TLA participation require the signature and seal/stamp of a civil engineer (CE)?**

**(Florida)** Structures, roadway lighting, sound walls, roadways, drainage, signage and pavement marking, utilities, [maintenance of traffic], [intelligent transportation systems], mitigation plans, stormwater management permits applications to state and federal agencies. Typically, any plan other than a landscape or irrigation plan. Occasionally, incidental hardscape is sealed by landscape architect.

**(Nevada)**

1. Plans for structural elements such as bridges, foundations, retaining walls exceeding 3 feet in height, etc.
1. Roadway plans including bike and pedestrian facilities.
2. Hydraulic plans and reports.

**(New York)** Once again, this would follow the Engineering Instruction cited above and the professional judgment of the licensed professionals on the team and the responsible department managers. The vast majority of NYSDOT projects are an amalgam of professional activities, some of which are outside the responsibility of a landscape architect such as structural design and pavement design. Therefore, the vast majority of projects and documents, even if some components are signed and sealed by LAs, would ultimately require the seal and signature of a civil engineer.

**(Oregon)** A CE may seal the erosion control plans and specifications if they are trained and otherwise qualified, or following consultation with the landscape architect. Architectural treatments on structures are sealed by a CE structural designer.

**(Texas)** (Central Office) Traffic control plans, structural retaining walls, major drainage structures. (District) Traffic control plans and anything outside the scope of an LA per the state licensing board.

**(Washington)** Hydraulic, in-channel work; roadway work.

**3. Are there project documents that can be signed/sealed by either a TLA or CE? Please describe.**

**(Florida)** State statutes give landscape architects broad authority to sign and seal project documents. FDOT, however, has a narrow understanding of the profession or its statutes. Typically, only landscape plans and irrigation plans are signed and sealed by landscape architects. Everything else is the engineer of record.

**(Nevada)** There is some overlap between what an LA and a CE can design and stamp under NRS/NAC (state law). But in general we require that the LA design be stamped by a registered LA. Any elements that are part of the LA design that can't be stamped by an LA are then stamped by a CE, such as foundations for sculptural elements.

**(New York)** This is possible. Drawings for sidewalk projects, small walls and structures (such as kiosks or decks), though within the purview of an LA, might also alternatively be signed by a PE.

**(Oregon)** Erosion control plans and specifications. These can also be sealed by registered geologists.

**(Texas)** (Central Office) Site plans, grading plans, sidewalk/pedestrian plans. (District) Enhancements, pedestrian improvements, erosion control. Many CEs are willing to seal any type of work.

**(Washington)** I have dual stamped stream channel plans with a PE.

**4. How is the scope of authority and responsibility of a TLA different from or similar to, or how does it overlap with, that of a CE within your agency?**

**(Florida)** Equal to an engineer based on each professional's area of expertise as recognized by FDOT. As stated above, this limits the authority, responsibility and opportunity for landscape architects.

**(Nevada)**

1. Erosion control, revegetation methods, and drainage are sometimes shared scope on a project. Both the CE and LA work jointly on these responsibilities, but the CE will ultimately have authority over the hydraulic design.
2. In general the authority and responsibility for an LA are similar to a CE. There are phases of work where the CE has a higher level of responsibility or authority. This generally occurs in the construction phase. The resident engineer in charge of overseeing the construction of the contract has final say on both LA and CE elements.

**(New York)** LAs in the department have authority and responsibility across the regions to fulfill any state-mandated requirements controlled by licensure as described in the prior answers. LAs are exclusively responsible for certain activities and areas such as planting,

aesthetics, the layout of landscape features, visual impact assessments and context-sensitive material selection.

But aside from these, many general administrative and supervisory responsibilities can be filled by either an LA or PE or environmental specialist such as managing a squad, planning activities, public outreach, drafting of guidance documents, GIS analysis, consultant management, local project administration, etc.

**(Oregon)** Both are very similar.

**(Texas)** (Central Office) Authority and responsibility are very similar when projects fall into the respective areas of responsibility. Those areas with overlap of responsibilities are handled project by project. (District) CE authority overrides LA.

**(Washington)** We don't have many CEs at this time. When we did, we worked with the CE on grading plans to meet both our objectives. Our stamping authority policy linked above provides pretty clear guidance about who stamps what.

**5. Has your agency identified areas of conflict with regard to the roles, responsibilities and signing authority of TLAs and CEs working together on transportation projects? If yes, how have you resolved those conflicts?**

**(Florida)** The only area of conflict is on drainage plans. Though state statute allows either licensed professional to sign and seal, the agency continues to rely exclusively on the engineers.

**(Nevada)** We have not experienced conflicts; rather, the LA will often times use different methods of achieving erosion control or drainage requirements and work as a team member to offer suggestions for achieving these requirements in more attractive manner.

**(New York)** No. See answer to question #1 in this section.

**(Oregon)** No.

**(Texas)** (Central Office) There are areas where signing authority can be conflicting, though we usually establish early in project development what those responsibilities will be. One area we have discussion on is the issuance of "standard" sheets. [M]ost of TxDOT standards are engineering-related and fall under the auspices of the board of professional engineers. (District) TxDOT has not identified areas of conflict, but CEs will design and seal work which is beyond their training.

**(Washington)** Good working relationships and clear communication and a clear policy.

## **Wrap-Up**

### **1. Do you have other comments you'd like to offer about an issue related to TLAs in your agency that we haven't addressed?**

**(Florida)** FDOT is currently working to include landscape architects into all roadway planning and design processes to accommodate existing and proposed landscapes. There is increased recognition here of the value and importance of the natural and scenic beauty of Florida. Florida is also relying on landscape architects to develop guidance for making stormwater facilities an attractive resource.

**(Nevada)** [No response.]

**(New York)** None.

**(Oregon)** [No response.]

**(Texas)** (District) Roles of TLAs vary between districts. Some are limited to maintenance work (roadside vegetation) and landscapes around the office buildings. These are often the smaller districts. TLAs in larger urban districts are typically also involved in roadside aesthetics, structural aesthetics, environmental projects, and enhancement designs.

**(Washington)** As in most other areas, clear communication, mutual respect, and good working relationships are key to working with any discipline smoothly.



Approved:

Effective: December 2, 2003  
Office: Environmental Management  
Topic No.: 650-050-001-e

---

José Abreu, P.E.  
Secretary

## **HIGHWAY LANDSCAPE, BEAUTIFICATION, AND PLAN REVIEW**

### **PURPOSE:**

To provide for the conservation of natural roadside growth and scenery and for the implementation and maintenance of roadside beautification programs. To provide safe, aesthetic, environmentally sound, cost effective, and manageable roadways. To establish a uniform statewide process for review of landscape plans, and for administration of the Florida Highway Beautification Council Grant Program.

### **AUTHORITY:**

Article II, Section 7(a), Constitution of the State of Florida  
Sections, 339.24, 339.2405, 334.044, Florida Statutes (F.S.)  
Rule Chapter 14-40, Florida Administrative Code (F.A.C.), Highway  
Beautification and Landscape Management

### **SCOPE:**

District Secretaries, District Operations, District Legal, District Work Program, District Financial Services Office/Disbursement Operations Office, District Planning, District Design, District Construction, District Maintenance, District Environmental Management, Central Environmental Management. This procedure affects all Florida Department of Transportation personnel, responsible for administering or reviewing landscape plans or projects.

### **REFERENCES:**

- Most Florida Department of Transportation (FDOT) publications are available at the Maps and Publication Sales Office, 605 Suwannee Street, Tallahassee, Florida 32399  
Website, <http://www.dot.state.fl.us/MapsAndPublications/>
- Phone (850) 414-4050, Suncom 994-4050, fax number (850) 414-4915, Suncom 994-4914. FDOT procedures are available on DOT INFONET
- Florida Highway Landscape Guide
- FDOT Environmental Policy, Topic No: 000-625-001,
- FDOT Design Standards, Topic No. 625-010-003
- FDOT Project Development and Environment (PD&E) Manual, Volumes 1 & 2, Topic No. 650-000-001

- FDOT Plans Preparation Manual, Topic No. 625-000-005
- FDOT CADD Manual, Topic No. 625-050-001
- FDOT Drainage Manual, Topic No. 625-040-001
- Highway Beautification and Landscape Management Rule Chapter 14-40, F.A.C.
- FDOT Highway Beautification Council Grant Application
- FDOT Highway Beautification Council Handbook, Environmental Management Office.
- FDOT Standard Specifications for Road and Bridge Construction
- FDOT Utility Accommodation Manual, Topic No. 710-020-001
- FDOT Contract Funds Approval Manual, Topic No. 350-020-200
- FDOT Pedestrian and Transit Friendly Manual
- FDOT Maintenance of Traffic Training, Topic No. 625-010-010
- Manual of Uniform Minimum Standards for Design, Construction and Maintenance for Streets and Highways. Rule Chapter 14-15, F.A.C.
- A Policy on Geometric Design of Highways and Streets, AASHTO
- The New Royal Horticultural Society Dictionary of Gardening
- Introduction or Release of Plant Pests, Noxious Weeds, Arthropods, and Biological Control Agents, FDACS Rule Chapter 5B-57, F.A.C.
- Florida Prohibited Aquatic Plants, Florida FDEP Rule Chapter 62C-52, F.A.C.
- Grades and Standards for Nursery Plants, 1998 FDACS Division of Plant Industry
- Florida Accessibility Code for Building Construction, FDCA

## **GENERAL:**

This document establishes processes for reviewing landscape plans, administering the Florida Highway Beautification Council Grant Program, and tracking expenditures for highway beautification projects. No installation, alteration, or removal of any landscape materials (excluding routine maintenance and work approved by **General Use Permits**) shall be performed on FDOT right of way prior to written approval by the District Landscape Architect (DLA). Where and when deemed appropriate by the DLA, the DLA shall initiate the plan review process and recommend the issuance of necessary permits and agreements.

## **DEFINITIONS:**

Definitions are found in Rule Chapter 14-40, Florida Administrative Code.

## **1. DISTRICT LANDSCAPE ARCHITECT (DLA)**

Each District Secretary shall appoint a District Landscape Architect. The DLA shall be a Registered Landscape Architect able to practice landscape architecture pursuant to **Chapter 481, Part II, F.S.** The DLA should have knowledge of FDOT rules, **Design Standards, Topic No. 625-010-003**, and

**Standard Specifications for Road and Bridge Construction** related to landscape architecture. The DLA may be responsible for project management and coordination of the review of landscape plans prepared by the Department (in-house), consultants, local governments, or individuals. The DLA will work with and assist local governments, community organizations, and the Department's neighbors on highway landscape related matters. The DLA will be available to assist all units of the District Office, and assist in the provision of landscape architectural design services in the planning, project development, design, construction, and maintenance of state roads. When landscape projects are to be designed by Department consultants, the DLA shall participate in the development of the **Scope of Services** for consultant contracts.

## 2. LANDSCAPE PLAN REVIEW PROCEDURE

**2.1** Landscape plans developed with roadway projects, or stand alone landscape design projects administered by the Department should be included with review submittals as specified in the **Plans Preparation Manual (PPM), Topic No. 625-000-005** and processed accordingly.

**2.2 All other Landscape Plans** shall be submitted to the District Office, and shall be reviewed for completeness. When it is determined that a landscape plan (plan) is complete, it is ready for the review process. There are no phase reviews in this procedure. Landscape architects should be encouraged to work closely with the DLA from the beginning of the design process. Only minor revisions should be needed following the review.

**2.3** When plans and related documents are complete, and meet the requirements of **Rule Chapter 14-40, F.A.C.**, the plans and related documents will be distributed to the units listed in **Section 3**, and to the Federal Highway Administration (FHWA) for projects on interstate highways. Appropriate time should be allowed for unit reviews. Each individual unit will be responsible for reviewing landscape plans in the allotted time, checking for compliance with the FDOT standards as they are listed below. All units should make an on site review of the project area with the proposed plans in hand. When appropriate, reviews by local governments, transit agencies, garden clubs, etc. should be administered to seek comments regarding community preferences, ordinances, and maintenance obligations.

**2.4** All comments shall be written (typed), with clearly marked plans as a supplement, making it unlikely that comments will be overlooked or misunderstood. The person making comments from each unit must sign and print their name and title near the title block of sheet 1 of the landscape plan. All plan sets should then be returned to the DLA, to coordinate the comments before making recommendations to the party submitting the plans or recommending action by the Department. The District should maintain a record of the review process in a permanent file in accordance with Department retention policies.

**2.5** Approved landscape plans shall be forwarded to the District Maintenance Engineer or designee (DME) for permitting or approval of agreements. Plans that cannot be approved by the DLA should be returned with recommendations and notice that plans can be resubmitted until approval is granted.

**2.6** Resubmitted plans need only be checked by the DLA before final approval is given. The DLA shall sign the final plans near title block of sheet 1. Units may request, but are not required, to recheck revised plans unless the DLA requests that a unit recheck a plan prior to final approval. If modifications to the plan are extensive, or beyond the comments made, the plan should be treated as a first submittal and rechecked by all units.

**2.7** When a landscape plan has been approved, the State Outdoor Advertising Administrator shall be notified by email, indicating the start and end points of the project with RCI Section, mileposts.

### **3. UNIT REVIEW RESPONSIBILITIES**

**3.1** All plans shall be checked for compliance with criteria established in ***Rule Chapter 14-40, F.A.C. Highway Beautification and Landscape Management***, other Department policies, rules, and standards as applicable. Review criteria are listed below. It may be necessary for more than one unit to review for compliance with the same criteria, taking into consideration the unit's area of responsibility and expertise. With consideration of each District's organizational structure, and the abilities and qualifications appropriate personnel in Planning, Environmental Management, Design, Traffic Operations, Utilities, Construction, and Maintenance should be assigned to review plans using the following evaluation criteria:

#### **3.2 Review Criteria**

- Compliance with ***Rule Chapter 14-40.003, F.A.C.***
- Compatibility with local indigenous plant communities and soil types.
- Introduction of invasive exotic plants.
- Use of Xeriscape principles.
- Cost effectiveness.
- Evidence of the appropriate environmental permits from other agencies.
- Availability of plant species.
- Appropriate protection measures for existing trees, endangered, desirable plants, and natural areas.
- Plant selection and placement.
- Protection and preservation of cultural resources.
- Compliance with FDEP permits.
- National Environmental Policy Act documentation and approvals (See ***PD&E Manual Volumes 1&2, Topic No. 650-000-001***).

- Verify that legally permitted (existing and proposed) outdoor advertising signs will not be screened.
- Local comprehensive plan requirements.
- Compatibility with requirements of local Metropolitan Planning Organization.
- **Florida Accessibility Code for Building Construction.**
- Compatibility with 5 year work plan.
- Compatibility with pedestrian, transit, and bicycle facilities.
- Impacts and compatibility with adjacent land uses and other local improvement projects.
- Compliance with **Title 23 CFR** planning requirements and other pertinent requirements such as conformity with **Department's Long Range Transportation Plan.**
- Compatibility with drainage structures, conveyances, and facilities.
- Compliance with appropriate erosion control procedures and the **FDOT Drainage Manual, Topic 625-040-001.**
- Compliance with the following FDOT **Design Standards**
  - **Index 544 Landscaping.**
  - **Index 546 Sight Distance at Intersections.**
  - **Indices 600-660 Traffic Control Plans.**
  - **Index 700 Roadside Offsets, and PPM, Volume I, Table 2.12.1 Horizontal Clearance and Clear Zone),**
- Compatibility with and any design or re-design of the subject roadway section, including theme, design intent, or master design guidelines for the region and/or District (i.e. native, historical, unifying elements, etc).
- Compatibility with any construction projects.
- Compatibility with signs (existing and proposed), signals, roadway lighting, closed circuit TV cameras, with accident investigation site layouts, and lightning protection systems.
- Maintenance costs, feasibility, level of maintenance, mowing, pruning, and watering.
- Maintenance impacts including coordination with existing permit requirements (Department of Environmental Protection, mitigation site, water management District, county, and city), general use permits, vegetation management permits, driveway permits, existing agreements.
- Verify that all necessary landscape maintenance is appropriately addressed in proposed agreements.
- Technical specifications.
- Compatibility with utilities, coordination with utility companies, and for proper annotation and location (horizontal and vertical) of existing and proposed utilities. **Utility Accommodation Manual, (Topic 710-020-001),**

## 4. POST CONSTRUCTION REVIEW AND CERTIFICATION

**4.1** On all landscape projects, the party initiating any landscape project (local government, grant applicant, consultant, etc.) is responsible for preparing and submitting accurate as-built plans or a summary of changes prior to approval of final invoice.

**4.2** On all landscape projects, excluding projects installed by the Department, routine maintenance, and work approved by **General Use Permits**, a copy of the as-built plans must be affixed to the maintenance agreements for permanent record. Any changes during the construction of a project must be noted and added to the final roadway file plans or as-built plans and maintenance agreements for permanent record.

**4.3** Each District should inventory all landscape maintenance agreements. During routine travel, personnel should review of all right of way covered by the agreements to verify that all landscape projects are properly maintained as required. When necessary, appropriate action must be taken to enforce the agreement.

## 5. FLORIDA HIGHWAY BEAUTIFICATION COUNCIL GRANT PROGRAM

**5.1** Each District Maintenance Engineer (DME) shall appoint a District Highway Beautification Council Grant Coordinator (Grant Coordinator). The Grant Coordinator will promote the FHBC grant program to potential applicants, will assist applicants through the grant application process, will represent the respective FDOT District at FHBC meetings, will work with the DLA to assure satisfactory completion of all landscape projects funded with FHBC grants, will prepare and transmit forms as required for the financial tracking and payment of FHBC grant projects, and will work with the State Transportation Landscape Architect (STLA) to maintain a uniform statewide FHBC grant program. The Grant Coordinator will maintain complete, accurate, and accessible files for each grant in a manner such that documentation can be produced for inspection or review when necessary.

**5.2** Promotion of the FHBC grant program: The Grant Coordinator will inform communities and other potential applicants about the FHBC grant program through newsletters, websites, workshops, meetings, or other public presentations. **Florida Highway Beautification Council Grant Application, Form No. 850-060-01** will be available on-line from the Department's Forms Library or from the Grant Coordinator.

**5.3** Application process. The Grant Coordinator shall be available by **July 1**, each year to receive DRAFT grant applications. This provides 90 days to review, revise, and approve the applications before the **October 1**, application deadline.

Upon receipt of each complete application, the Grant Coordinator will sign the application, and log in (See ***FHBC Handbook***) the application by recording the applicant name, contact information, project description, county, SR#, US#, requested grant amount, estimated matching amount, and estimated total project cost, and District totals. Upon receipt of each approved application, the Grant Coordinator shall send a ***Confirmation of Receipt email or letter*** (See ***FHBC Handbook***) to notify the applicant of receipt of the application. Incomplete or ineligible applications should be returned to the applicant with an appropriate explanation.

**5.4** By **November 1**, the Grant Coordinator shall send to the STLA, via email, the District log in list (See ***FHBC Handbook***). The Grant Coordinator will send, via interoffice mail, eight copies of each application to the STLA.

**5.5** By **November 15**, The STLA shall compile statewide log in list, and distribute the list and each application submitted by Grant Coordinator to the FHBC.

**5.6** The STLA shall schedule and make all necessary arrangements for the ranking meeting on or about **January 15** per direction of the Council chair. Public notice of all FHBC meetings is required and can be coordinated through the Office of General Counsel. The Grant Coordinator or designee shall attend the FHBC ranking meeting to represent the District. During the ranking meeting, the STLA shall record each FHBC member's score for each application, and average the results for the final ranking score of each application. After scoring all applications, the STLA will collect all score sheets from FHBC members, and maintain as part of meeting minutes. The STLA shall develop a ***Ranked Listing*** (See ***FHBC Handbook***) of the projects. After development of the ***Ranked Listing***, the STLA must request a ***Reviewed Funds Approval*** from the Contract Funds Management (CFM) section via email (FI989JJ/CFM Coordinator). The CFM section will send an email back to the STLA stating that "funds have been reviewed". The STLA will then distribute the ***Ranked Listing*** to Grant Coordinators and for publication at the time of award of the grants.

**5.7** Beginning with the highest (#1) ranked project, grants are awarded in the ranked order until the remaining budget is not enough to fund the next ranked project. The letter offering the grant awards shall be addressed to the applicant as listed in the application package, and sent by certified mail with return receipt for proof of delivery. Referenced in the letter shall be:

- the fiscal year of the grant award,
- financial project number,
- project description,
- grant and matching amounts,
- conditions for grant award,
- statement concerning the responsibility of the applicant to ensure that all agreements associated with the grant proposal are fully executed within one year from date of the award letter,

- statement that there is no commitment of funds for the grant project until the **Notice to Proceed** is issued, and that expenditures for work prior to the **Notice to Proceed** are not reimbursable, and
- direction for accepting the grant by sending a certified letter to the Grant Coordinator so stating within a period of 15 days from the date of the offer of the award.

**5.8** The Grant Coordinator shall inform the STLA upon receipt of the acceptance. The Grant Coordinator shall provide written notice to all applicants not receiving awards, and provide the Council's attribute scores and comments.

**5.9** . Immediately after the **Offer of Award Letters** are signed and sent to the respective ranked grant applicants, the STLA shall request the Budget Office to transfer the proper grant funds to each District (See **FHBC Handbook**). The budget should be transferred to each participating district before funds may be encumbered through the CFM system. After completion of the transfer of funding, the STLA shall transmit to all Districts a **Transfer of Funding Notification** (See **FHBC Handbook**) listing the transferred funds noting the account numbers and amounts transferred. Immediately after the notification of budget transfer, the Grant Coordinator must encumber funds through the CFM system. The CFM system will then generate an e-mail to the requestor verifying that funds are approved. The e-mail shall be printed and placed in the project file for clarification of funds approval.

**5.10** The Grant Coordinator should advise the recipient that landscape plans for the grant project must be approved by the DLA before execution of a Construction and Maintenance Agreement, and that the Construction and Maintenance Agreements must be executed within one year of the execution of the FHBC/MOA. All agreements must contain beginning and ending dates, and include specific deliverables (allowable grant costs) which are in accordance with **Section 339.2405(11), F.S.**

**5.11** Prior to construction of the grant project, a pre-work conference may be held by the Unit Maintenance Project Manager. Prior to the **Notice to Proceed** being sent to the recipient as listed in the original application package, the Grant Coordinator must verify that funds have been encumbered. When the **Notice to Proceed** is sent, a copy of the **Contract Status Change Notice** should be sent to the District/Central Office Contract Status Change person.

**5.12** The Grant Coordinator shall maintain a project file for each grant. This file shall contain a completed application package, all ranking information, certified mail receipt and copy of the **Offer of Award Letter, Letter of Acceptance**, copies of the applicant's dated resolution, executed agreements, copy of the **Notice to Proceed**, all correspondence, copy of the **Contract Funds Management Approval e-mail** and copies for the **Contract Status Change**. By January 31, and July 31 of each year the Grant Coordinator shall compile a



report on the status of all active grants and grants closed during the previous 6 months. Copies of all documents should be available for review.

**5.13** Upon receipt of a **Notice of Completion** (See **FHBC Handbook**) and as-built drawings accompanied by all original invoices from the recipient, the Grant Coordinator shall make a final inspection of the project to ensure the project has been completed in compliance with the awarded grant and approved plan. Prior to processing the final reimbursement, a written record of the final inspection and acceptance of completed project must be in the grant project file. After the final inspection and acceptance of the work, the Grant Coordinator shall accept a proper invoice for payment of project from the recipient and submit the invoice for payment to the District Financial Services Office or Disbursement Operations Office as appropriate.

**5.14** For Final Payment, the recipient shall provide the Department the following: a fully itemized invoice indicating "Final"; a written and signed certification that the Highway Beautification Project was constructed in compliance with the approved plan and specifications. Invoices for all grant related expenses to be paid by the Department must be reviewed by the Grant Coordinator to verify that only the following items are paid: items delivered and properly installed as approved by the Department and the FHBC, items that are allowable grant costs as described in **Section 339.2405(11), F.S.**

**5.15** The Grant Coordinator shall compile a **Final Payment Package** with the as built plans and completed **Form No. 350-060-02, Contract Invoice Transmittal** (See **FHBC Handbook**). When approved, approval shall be noted on the invoice and the **Final Payment Package** shall be submitted to the District Financial Services Office/Disbursement Operations Office in a timely manner for prompt payment. Once the final payment is completed, the Grant Coordinator shall prepare a **Contract Status Change, Form No. 350-020-06** and submit the form to the District/Central Office Contract Status Change person for closure of the contract. The CFM system will remove all remaining funds on the contract.

## 6. TRAINING

Training and technical support necessary to implement this procedure are available, upon request, from the Central Environmental Management Office.

## 7. FORMS

FDOT forms are available to download from the FDOT INFONET (INTRANET). Go to Offices, then to Organization, Forms and Procedures.

- Form No. 350-060-02 (Comptroller-Disb Operations), Contract Invoice Transmittal.
- Form No. 375-020-03 (Contracts Administration), Notice of Beginning and

- Completion of Maintenance/Construction Projects.
- Form No. 350-020-06 (Comptroller-fin Management), Contract Status Change/Checklist.
  - Form No. 650-050-06 (Environmental Management Office) Application for Vegetation Management at Outdoor Advertising Signs.
  - Form No. 650-050-08 (Environmental Management Office) Permit for Vegetation Management at Outdoor Advertising Sign. Copies of the permit form placard are available from the Central Environmental Management Office.
  - Form No. 850-060-01 (Environmental Management Office) Florida Highway Beautification Council Grant Application.

STATE OF FLORIDA  
**POSITION DESCRIPTION**

250-020-10  
PERSONNEL/DMS  
12/10

<b>CAREER SERVICE</b> <input checked="" type="checkbox"/> <b>SELECTED EXEMPT SERVICE</b> <input type="checkbox"/> <b>SENIOR MANAGEMENT SERVICE</b> <input type="checkbox"/> <b>OTHER</b> <input type="checkbox"/>			
<b>POSITION LOCATION INFORMATION</b>		Position Exempt Under 110.205(    )(    ), F.S. Managerial <input type="checkbox"/> Confidential <input type="checkbox"/> Supervisory <input type="checkbox"/> Other <input type="checkbox"/>	
NAME OF AGENCY: <b>Florida Department of Transportation</b>		Organization Level: Current: <b>5520104010</b> Proposed: <b>5530201080</b>	
DIVISION/COMPARABLE: <b>Assistant Secretary Engineering and Operations</b>		Position Number: <b>55010085</b>	FTE: <b>1.00</b>
BUREAU/COMPARABLE: <b>State Highway Engineer/Office of Design</b>		Current Broadband Level Code: <b>17-1012-04</b>	Current Class Title: <b>Landscape Architect</b>
SECTION/SUBSECTION: <b>Production Support Office</b>		Proposed Broadband Level Code:	Proposed Class Title:
HEADQUARTERS/COUNTY CODE: <b>Leon / 37</b>		Type of Transaction:	
INCUMBENT: <b>Jeff Caster</b>		<b>APPROVAL AUTHORITY USE ONLY</b>	
<b>POSITION ATTRIBUTES:</b> EEO: 01 <input type="checkbox"/> 02 <input type="checkbox"/> 03 <input type="checkbox"/> 04 <input type="checkbox"/> 05 <input type="checkbox"/> 06 <input type="checkbox"/> 07 <input type="checkbox"/> 08 <input type="checkbox"/> CBU: 01 <input type="checkbox"/> 02 <input type="checkbox"/> 03 <input type="checkbox"/> 04 <input type="checkbox"/> 05 <input type="checkbox"/> 06 <input type="checkbox"/> 07 <input type="checkbox"/> 08 <input type="checkbox"/> 09 <input type="checkbox"/> 10 <input type="checkbox"/> 11 <input type="checkbox"/> 18 <input type="checkbox"/> 80 <input type="checkbox"/> 81 <input type="checkbox"/> 86 <input type="checkbox"/> 87 <input type="checkbox"/> 89 <input type="checkbox"/> 99 <input type="checkbox"/> Other <input type="checkbox"/> _____ Special Risk: Yes <input type="checkbox"/> No <input type="checkbox"/> Overtime: Yes <input type="checkbox"/> No <input type="checkbox"/> CAD: Yes <input type="checkbox"/> No <input type="checkbox"/>		Broadband Level Code	Class Code
		Approved By	Effective Date:
		APPROVED BROADBAND OCCUPATION:	
		APPROVED BROADBAND CLASS TITLE:	
		WORKING TITLE: <b>State Transportation Landscape Architect</b>	
1. This position reports directly to: Position Number <b>55008625</b> Broadband Level Code <b>11-9041-03</b> Broadband Occupation <b>Engineering Managers</b> Class Code <b>8675</b> Class Title <b>Manager, Production Support Office</b>			
2. Broadband level code, class title, class code, position number, and headquarters location of each position which reports directly to this position:			
3. What statutes establish or define the work performed?			
4. This position has financial disclosure responsibility in accordance with Section 112.3145, F. S.: Yes <input type="checkbox"/> No <input checked="" type="checkbox"/>			
5. Current budget for which this position is accountable (if applicable): (include Budget Entity) <b>55100100 - Transportation Systems Development</b>			
_____ Salaries & Benefits	_____ O.P.S.	_____ Expenses	
_____ F.C.O.	_____ Data Processing	_____ TOTAL ALLOTMENT	
If the current budget includes other areas of accountability include them in the TOTAL ALLOTMENT and provide a brief explanation.			

6. Duties and Responsibilities - Describe in detail the specific duties and responsibilities assigned to this position and the percentage of time for each. Indicate the role of this position in accomplishing the unit and agency mission. If applicable, include examples of independent, final policy decisions made and show their effect on the agency, the public, or other state agencies.

% of Time  
25%

**Duties and Responsibilities**

**Assure the department meets the requirements of Section 334.044(26), Florida Statutes, 1.5% for highway beautification programs. Track landscape expenditures and commitments, and approve or disapprove exceptions during the annual review of the Tentative Work Program. Review and approve all landscape plans before letting. Implement consistent predictable and repeatable BOLD performing landscape program and projects. Coordinate the District Landscape Architects and Managers. Manage Central Office landscape architecture consultants. Review and approve Group 15 Consultant Pre-qualifications.**

25%

**Develop, maintain, sign, and seal all roadway landscape design criteria, standards, and standard specifications including, but not limited to Index 544 Landscape Installation; 591 Landscape Irrigation Sleeve; Developmental Design Standard 590 Landscape Irrigation; Plans Preparation Manual Volume I, Chapter 9 Landscaping, Volume II, Chapter 26 Landscape Plans, other relevant sections; Standard Specifications Section 580 Landscape Installation, and Landscape Irrigation Developmental Specification 590. Develop and Maintain Landscape Computer Aided Drafting and Design Standards. Update, as needed, Rule Chapter 14-40, Florida Administrative Code. Highway Beautification and Landscape Management. Update, as needed, the Highway Beautification Policy, and the Context Sensitive Solutions Policy, and the Highway Landscape Beautification and Plan Review Procedure, and the Wildflower Program Procedure. Develop and deliver guidance training, and instruction to design, construct, and maintain roadways that safely accommodate bold performing landscapes. Maintain Landscape Website.**

25%

**Coordinate Florida Highway Beautification Council and Grant Program, per Section 339.2405, Florida Statutes. Coordinate with Florida Forest Service and Florida Highway Patrol to implement and update the Highway Safety and Smoke Management Interagency Agreement. Maintain up to date landscape architecture standard scope and staff hour estimating guidelines. Represent Florida Department of Transportation and Coordinate with Transportation Research Board Landscape and Environmental Design Committee and the American Association of State Highway Officials Technical Committee on Environmental Design. Represent Florida Department of Transportation with industry partners including the Florida Federation of Garden Clubs, University of Florida Landscape Architecture Advisory Council, Florida Wildflower Foundation, the Florida Chapter of the American Society of Landscape Architects, and the Florida Nursery, Growers, and Landscape Association**

20%

**Manage Florida Scenic Highway Program consistent with Section 335.093, Florida Statutes.**

5%

**Perform other related duties as required.**

7. Knowledge, skills and abilities, including utilization of equipment, required for the position:  
**Knowledge of roadway landscape architecture design principles and fundamentals; knowledge of state and federal roadway and landscape regulations, guidelines, and standards; knowledge of Florida Department of Transportation policies and procedures related to landscape design standards and guidelines; knowledge of contracts management and personnel management. Skill in leading and managing individuals and groups; skill in applying landscape architecture principles and procedures to develop context sensitive solutions for transportation problems; skill in preparing written guidelines and procedures to describe processes; skill in developing and presenting training courses and programs; ability to work independently to solve complex problems; and ability to communicate and interact effectively with others inside and outside the Department to accomplish Department and Engineering and Operations goals and objectives.**

8. Licensure/registration/certification requirements (If applicable, list the appropriate Florida Statute or federal regulation cite):  
**Registration as Professional Landscape Architect (Florida Statute 481, Part II)**

9. Other job-related requirements for this position:

10. Working hours: (A) Daily from **7:00 a.m.**-to **4:00 p.m.** (B) Total hours in workweek **40** (C) Explain any variation in work (split shift, rotation, etc.) \_\_\_\_\_ (D) Work Week Type 5 - 08 (E) Shift Code Regular = 0

**11. Agency Use Only –**

Check those that apply: Uniform Allowance  CJIP  Bond Indicator  Drug Screening  Re-screening   
 Security Check: No security screen required  Background investigation required  Background & fingerprint required   
 Fingerprint investigation required  Access to abuse records  Caretaker  Financial  Law enforcement  Management   
Sensitive  Agency security check  **Other:** Purchasing Agent  Vendor Invoice/Warrant Processing   
Work with/around Department of Corrections Inmates  Drivers License Type  A  B  C  E  
 Present InterDept # : **09-9850-3000** Proposed InterDept # : **09-9720-3000**  
 PHYSICAL COUNTY/COUNTY CODE: **Leon / 37**

Changes to the Position Description: Indicate specifically what has changed in this position description since it was last updated, reclassified or add/deleted. Include specific functions or duties and/or responsibilities that have been added or taken away. **This position is being moved from cost center 985 to 972. Position description duties and responsibilities are updated to reflect related changes as a result of this action.**

**The following have acknowledged that the statements above, to the best of their knowledge, accurately describe the duties and responsibilities of the position.**

Incumbent signature:		Date:
Discussed with employee: Yes <input type="checkbox"/> No <input type="checkbox"/>	Title:	Date:
Supervisor's signature:	Manager, Production Support Office	
Approval of Reviewing Authority: (Division Director, Agency Head or other)	Title:	Date:
	Director, Office of Design	
Approval of Agency Personnel Officer:	Title:	Date:
	Director of Human Resources	

A scenic landscape photograph showing a paved road on the left that curves into the distance. A stone retaining wall runs along the edge of the road. To the right of the wall is a stream with several large rocks, surrounded by dense trees with vibrant autumn foliage in shades of green, yellow, and orange. The sky is a pale, overcast grey.

# Landscape Architects and NYSDOT's Project Development Process

April, 2009

# Objectives

- Understand what Landscape Architecture is
- Recognize what the LA license covers – how it affects the Health, Safety and Welfare of the public
- Comprehend the Legal Basis for the work performed by LA's on Transportation Projects
- Understand the value LA's add throughout the Project Development process to help our projects meet the stated goals and objectives of the Department



Successful Transportation Projects  
result from an inter-disciplinary  
project team effort

**Landscape Architects are a vital  
component of the project team.**



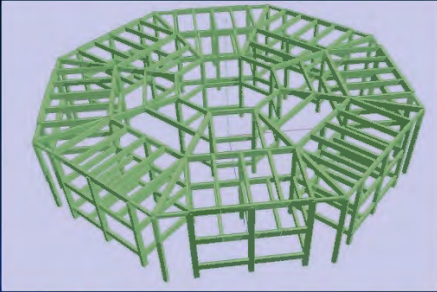

# The Design Professions:

- Professional Engineers
- Architects
- Land Surveyors
- Landscape Architects



# What is a Landscape?

- “A portion of territory that can be viewed at one time from one place.”

- Webster Dictionary

- “...composed of not only what lies before our eyes but what lies within our heads.”

- D. W. Meinig, The Beholding Eye

- “... the product of the appearance, uses and perceptions of places that are part of the outdoor environment.”

- Peter H Goodchild. The Garden and Landscape Heritage Trust

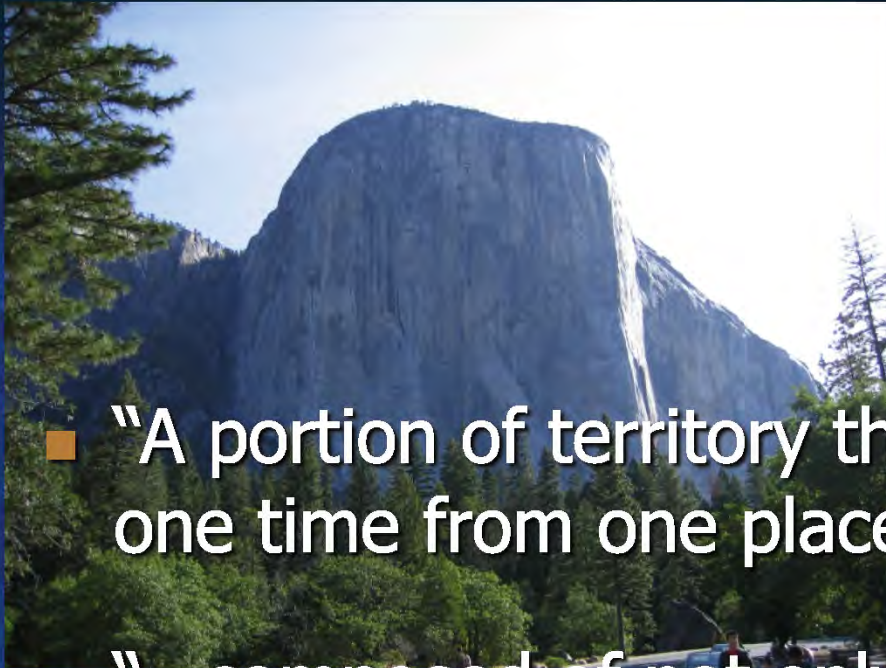

# How we view Landscapes

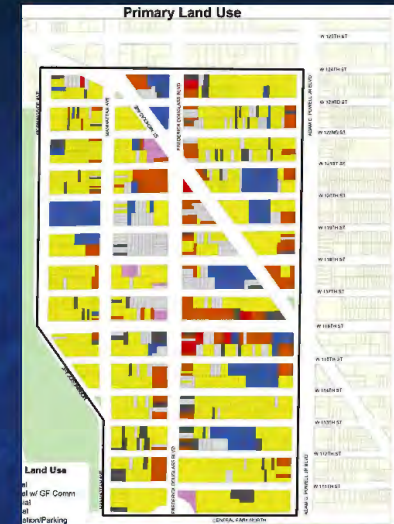
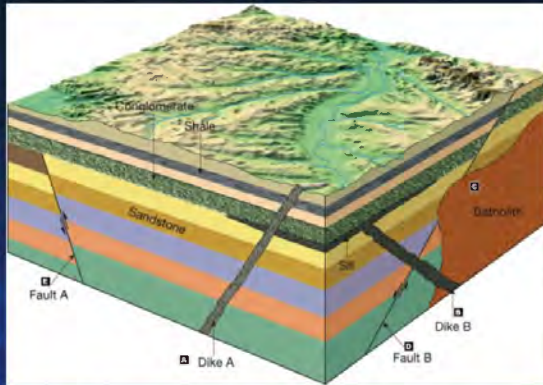

- Geologist – landforms
- Planner – human use patterns
- Ecologist – watershed, systems, habitat
- Designers/Engineers – problem solving
- Individuals – personal and public space
- Real Estate – ownership parcels
- Developer – business opportunity

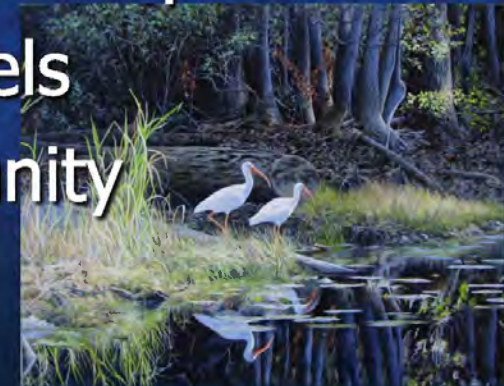

# Design on the Land

A long history of adapting landscapes on a large scale to suit needs, ideals, to make a mark.

- Stonehenge
- Pyramids and Sphinx
- Mayan Cities
- Acropolis
- St. Peter's Basilica
- Versailles
- Champs-Elysees
- University of Virginia

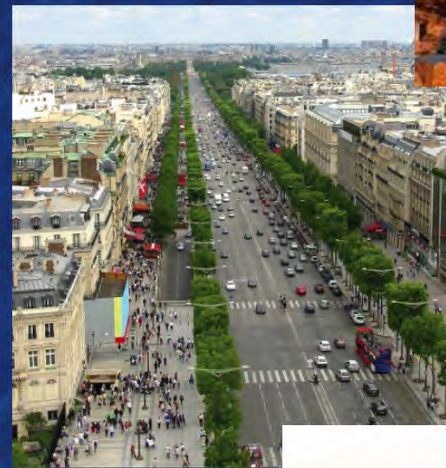



# Landscape Architecture as a profession:

- “Landscape Architecture” first used in Scotland, 1828 to describe elements of landscape painting (Gilbert Laing Meason)
- Used as a description of services by Andrew Jackson Downing in US early-mid 1800s.
- Used as a professional title by Frederick Law Olmsted in 1863.
- Became a licensed Profession in New York in 1961.

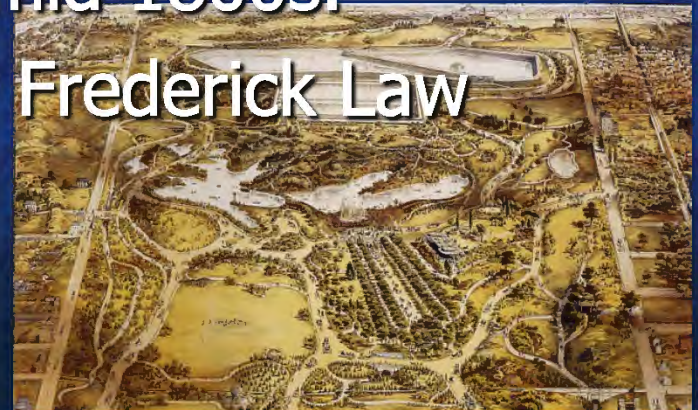

# Landscape Architecture:

- Architecture
- Civil Engineering
- Urban Planning
- Environmental Management
- Horticulture
- Aesthetics



# Landscape Architects:

- Analysis
- Planning
- Design
- Stewardship
  - of the Natural/Built Environment

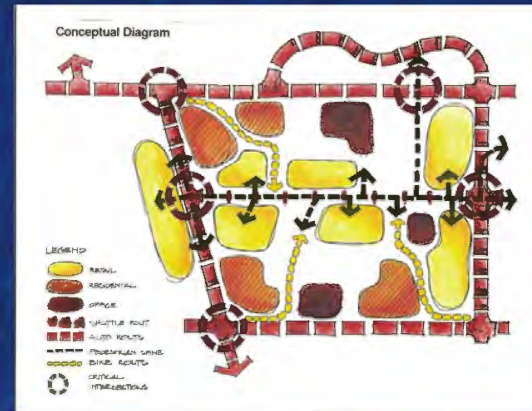

# Landscape Architects / Environmental Specialists?

Both are important members of a project team

## Landscape Architects:

- Design Professional - integrate environmental concerns with project design. Develop design alternatives that Avoid, Minimize, Mitigate, as well as enhance.
- Broad perspective – Well versed in most environmental issues. ID need for specific Environmental Expertise
- Balance competing issues - Consider aesthetics values in the decision making process along with Cost, Safety, Durability and Constructability of each alternative



# A Licensed Design Profession

## NYS Education Law, Section 7321

- .... preservation, enhancement or determination of proper land uses, natural land features, ground cover and planting, naturalistic and aesthetic values, the settings, approaches or environment for structures or other improvements, natural drainage and the consideration and determination of inherent problems of the land relating to the erosion, wear and tear, blight or other hazards.



# A Licensed Design Profession

## NYS Education Law, Section 7321

- This practice shall include the location and arrangement of such tangible objects and features as are incidental and necessary to the purposes outlined herein but shall not include the design of structures or facilities with separate and self-contained purposes such as are ordinarily included in the practice of engineering or architecture; and shall not include the making of land surveys or final land plats for official approval or recording.



# Why We do What We do at DOT

- NEPA – National Environmental Policy Act
  - 23CFR 771.105
  - (b) “...Balanced consideration..”
  - (c) “...Public involvement and a systematic interdisciplinary approach...”
- SEQRA – State Environmental Quality Review Act
  - “ ...A State Policy which will encourage proactive and enjoyable harmony between man and his environment...”
- 23 CFR 752 – Landscape and Roadside Development

# NYS DOT PROJECT DEVELOPMENT PROCESS

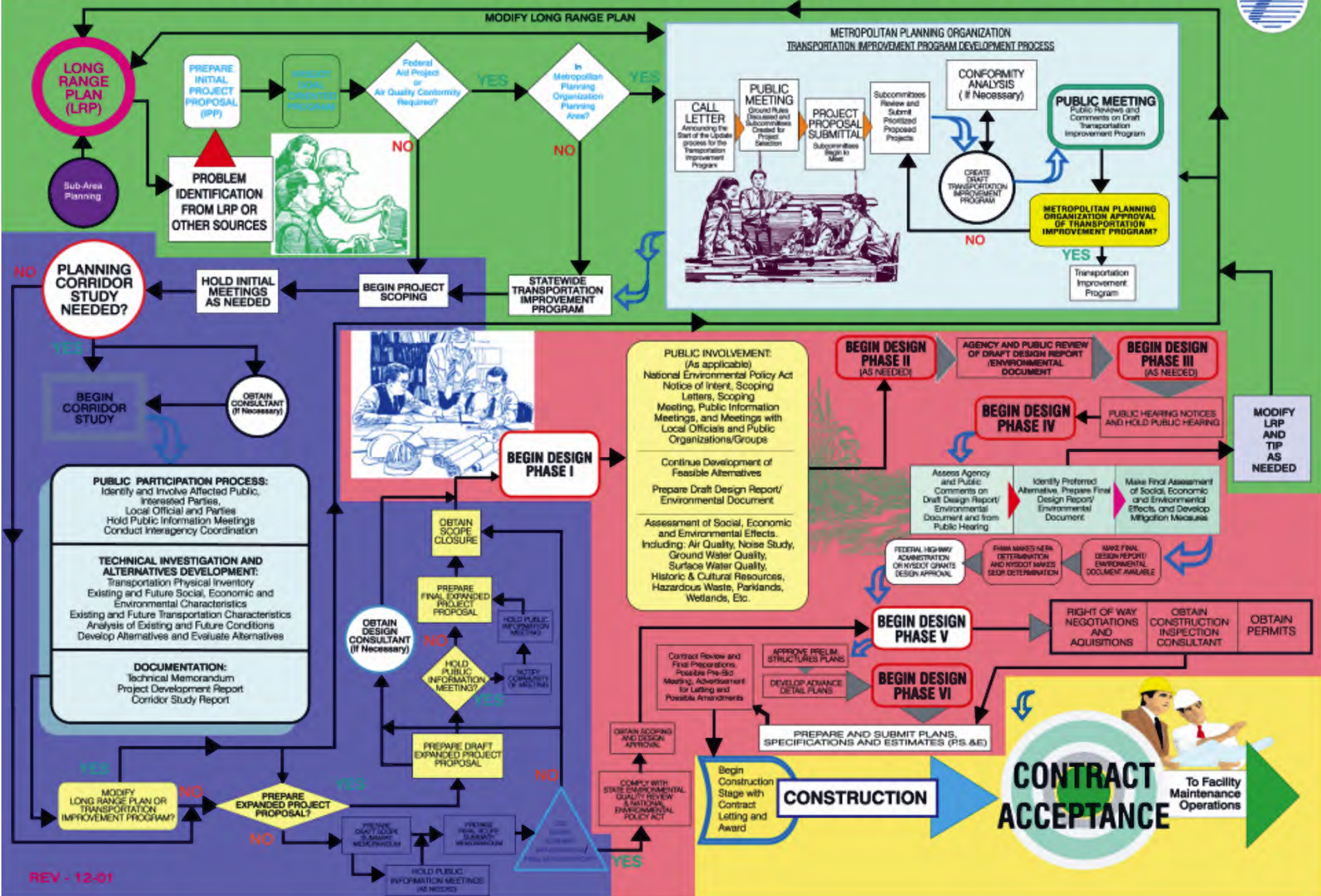

# Context Sensitive Solutions

- A collaborative, interdisciplinary approach that involves all stakeholders to develop a transportation facility that fits its physical setting and preserves scenic, aesthetic, historic and environmental resources, while preserving safety and mobility.
- ***This is how we do our business!***

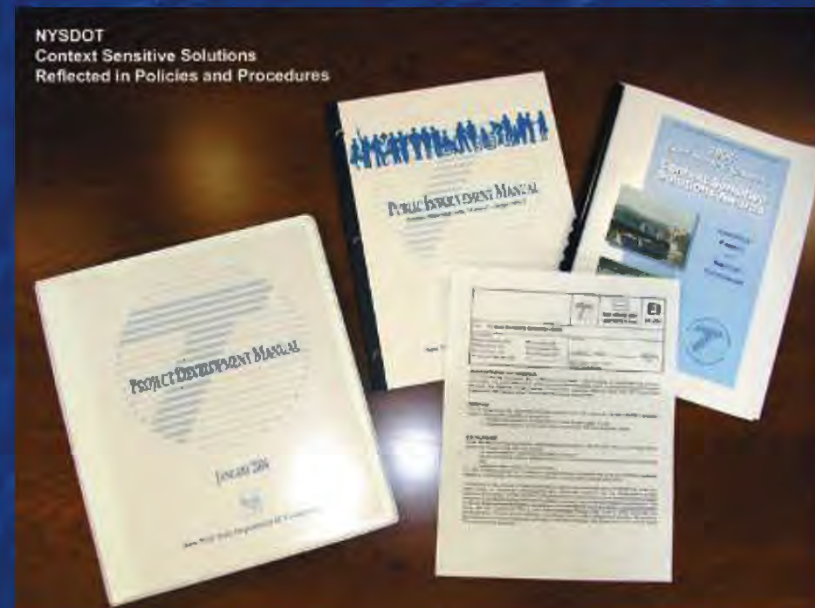

# Project Initiation

## IPP – Initial Project Proposal

- Planning and Programming Document used to select projects. Includes:
  - project description,
  - preliminary project purpose and need,
  - project elements to be investigated,
  - preliminary environmental classification,
  - identification of known community concerns and environmental issues,
  - Preliminary schedule and cost estimate.

# Role of the LA

- Context
  - Roadway Characteristics
  - Roadway Users
  - Historic Sites and Districts
  - Visual Resources
  - Community Values
  - Surrounding Land Uses

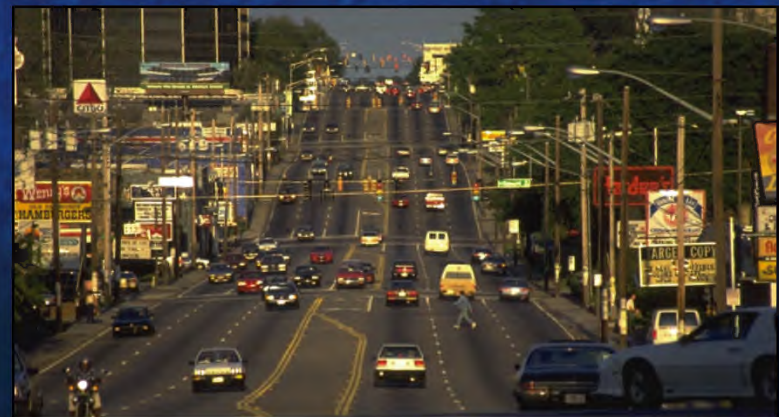
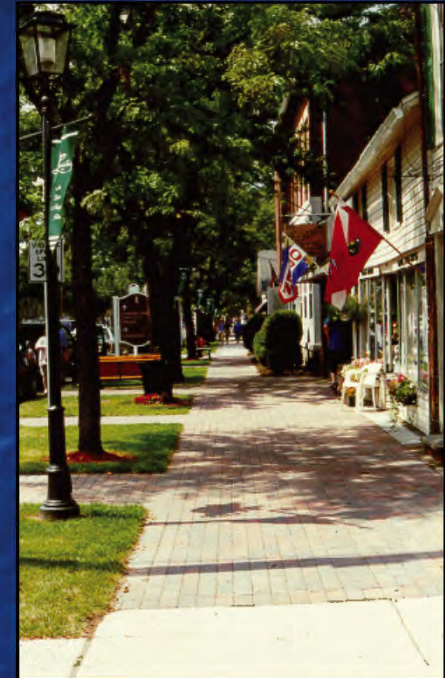

# Scoping

The right level of information to make the right decisions at the right time

- Transportation Conditions Inventory, Context Identification and Analysis
- Needs and Problem Identification
- Project Objectives
- Design Criteria
- Develop Feasible Alternative Solution(s)
- Identify Potential Social, Economic, and Environmental issues
- Determine Critical Path issues
- Develop Cost Estimate And Schedule



# Project Team

*Early, proactive involvement with the project team leads to successful transportation projects.*

## Team Leader

- Planning
- Design
- ITS Coordinator
- Structures
- Construction
- Traffic
- Utility Engineer
- Maintenance
- Landscape Architect
- Environmental Specialist
- Bike / Ped Coordinator
- Public Information Officer
- Geotech
- Materials
- EEODC
- Real Estate

# Scoping - Technical Process Planning and Scope Development

## Technical Elements / Issues (Landscape/Environmental)

- Context identification
- Quality Communities
- Pedestrian / Bicycle
- ADA Compliance
- Wetland Mitigation Design
- Visual Resources
- Aesthetics
- Planting / Landscaping
- Local Master Plans
- Vegetation Management
- Erosion Control
- Storm Water Pollution Control
- Parklands (4f)
- Social and Economic Impacts
- Water Resources & Wetlands
- Environmental Initiative
- Historic and Cultural Resources (Section 106)
- Environmental Justice



# Landscape Development and Aesthetics

- DOT LA's will evaluate aesthetics based on:
  - Context Identification
  - Public Outreach
  - Historic Considerations
  - Feasibility and Cost
  - Maintenance



# Inventory of Existing Site Features



Fig. 2-4 R  
Petersburg



Fig. Pete



n Troy



vicinity of Belden Pond alor



Fig. 5-15: Hudson River, T



Fig. 5-44: Sequential views descending Route 2 towards Petersburg; heading east. Illustrate the full range of roadside conditions found along Route 2.



Fig. 5-13: Grafton Lakes State Park



Fig. 5-14: Taconic Ridge at Petersburg Pass

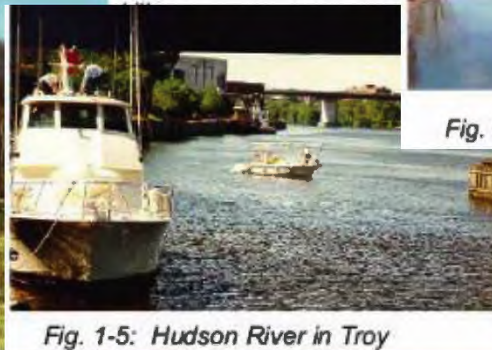

Fig. 1-5: Hudson River in Troy

# Architectural Context



# Community Characteristics



# Public and Agency Involvement



- Input into Public Involvement plan
  - Identify stakeholders and project type
  - Identify methods – charettes, visualizations'
- May be liaison with stakeholders, resource agencies
- Able to help communities identify and articulate their values and vision

# Charette Process

- Concurrence / emphasis on opportunities
- Review & concur on site parameters
- Preferred range & type of aesthetics
- Actively engage & involve stakeholders in decision making process
- Possibility of developing guidelines to complement project development e.g. visual quality & aesthetics guidelines

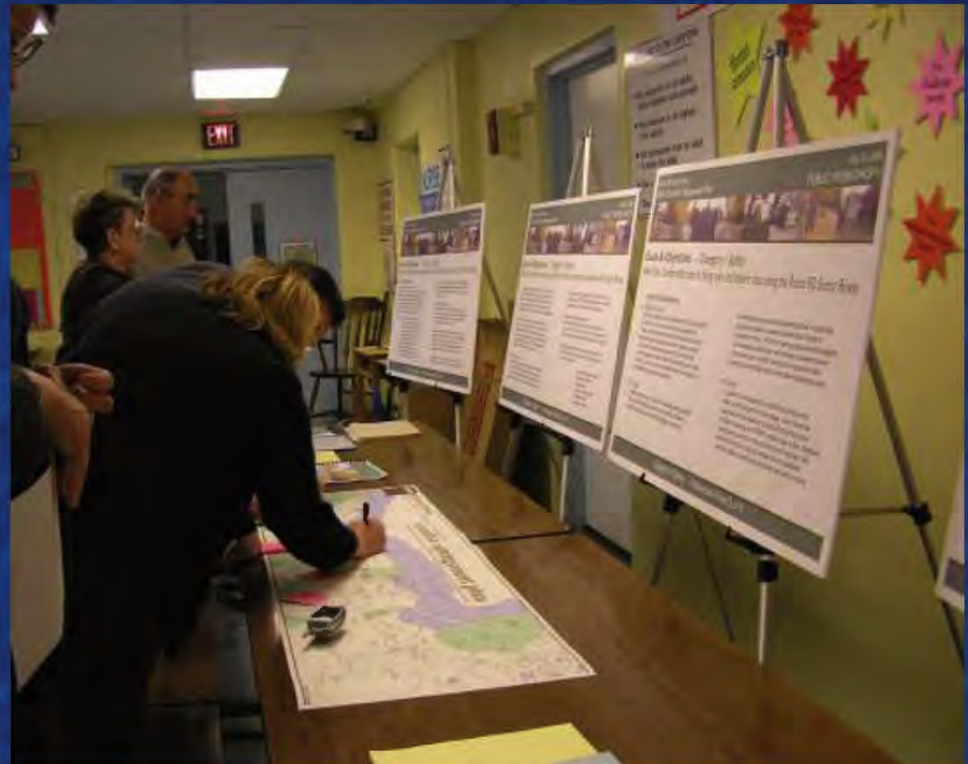

Region 8 – Port Ewen  
Public Charette



# Aesthetics Guidelines

- Troop Howell Bridge  
I-490 Corridor
  - Aesthetics Committee established to develop aesthetics goals for project corridor. Included citizens, artisans, municipal reps, DOT LA, DOT Project Manager
  - Guidelines used by design, structures
  - Prioritizes aesthetic elements

INTERSTATE 490 RECONSTRUCTION  
FROM  
THE ERIE CANAL TO THE GENESEE RIVER

## WESTERN GATEWAY PROJECT



## AESTHETICS COMMITTEE RECOMMENDATIONS

DRAFT REPORT  
DECEMBER 22, 1999

# Provisions for Pedestrians and Bicyclists

- Bike routes
- Sidewalks
- ADA
- Access to businesses
- Multi-modal
- Chapter 18 Pedestrian Generator Checklist



# Visual Resource Scoping Assessment



# GIS Environmental Viewer and Region Specific Arcview Environmental Applications

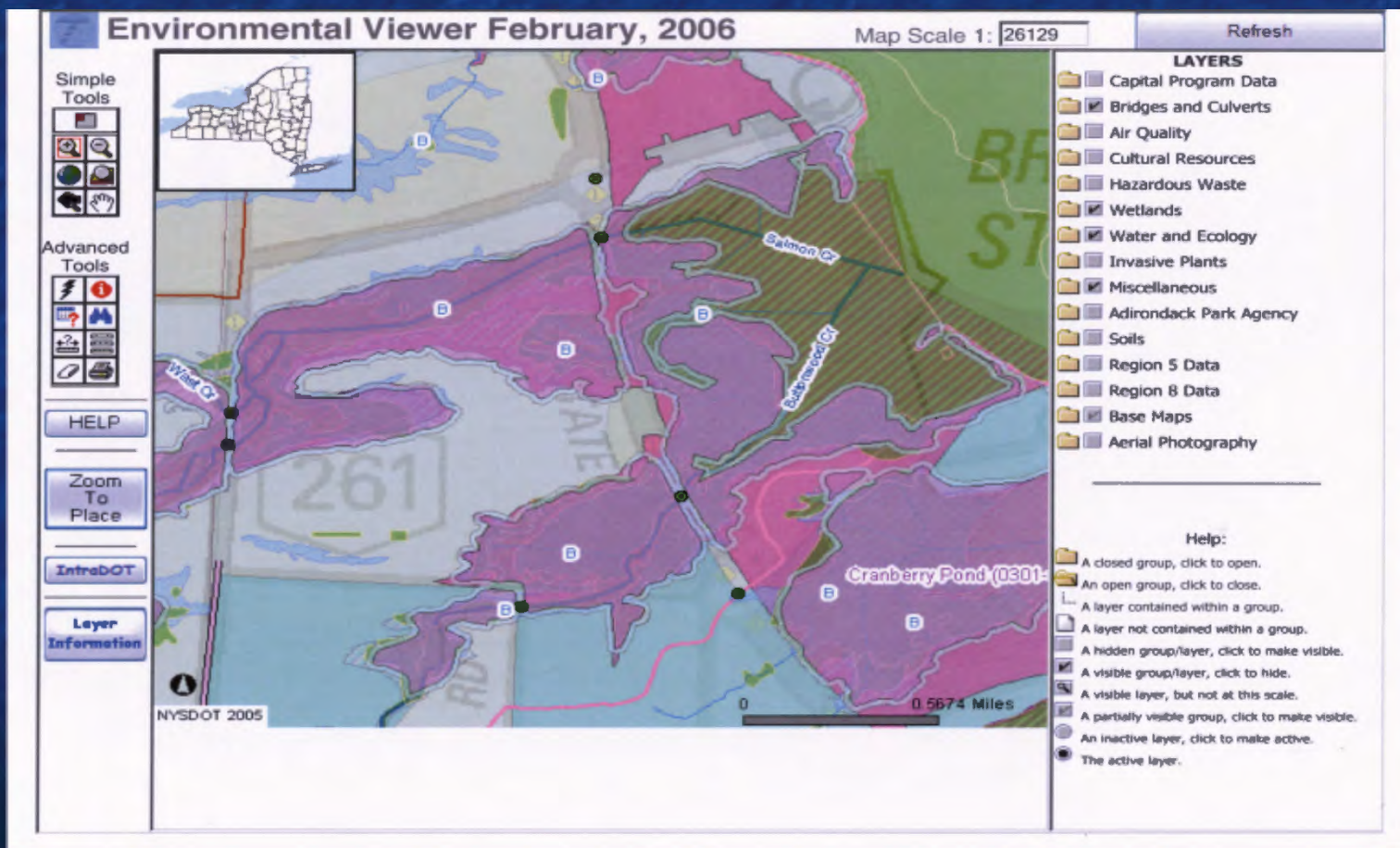

# ETRAK

Microsoft Access - [Env Check Form : Form]

File Edit View Insert Format Records Tools Window Help

Type a question for help

MS Sans Serif 8 B I U

## ENVIRONMENTAL CHECKLIST

**Close Form**

**PIN** [ ] [ ]

**DESCRIPTION** [ ]

**DATE** [ ]

**PROJECT MANG.** [ ]

**SEQR/NEPA** [ ]

**PS&E** [ ]

ENVIRONMENTAL ISSUE		COMMENTS
1. Parkland - State, County, Local Trails (Appalachian/Others)	[ ]	[ ]
2. (a) Individual or Programmatic Section 4(f)	[ ]	[ ]
(b) Section 6(f)	[ ]	
(c) Section 1010	[ ]	
3. Historic and Archeological Resources	[ ]	[ ]
4. Natural Landmark	[ ]	[ ]
5. Visual Resources	[ ]	[ ]
6. Coast Guard Bridge Permit	[ ]	[ ]
7. Floodplains	[ ]	[ ]
8. Wetlands/Federal	[ ]	[ ]
9. Executive Order 11990 (Individual or Programmatic)	[ ]	[ ]
10. Wetlands/State	[ ]	[ ]
(a) Art. 24 Permit (Freshwater)	[ ]	
(b) Art. 25 Permit (Tidal)	[ ]	
11. USACOE - Section 10 or 404 (Nationwide or Individual)	[ ]	[ ]
12. Water Quality Certification - NYSDEC Section 401	[ ]	[ ]
13. DEC Streams Disturbance Review (DEC/DOT Mou, Art. 15/24)	[ ]	[ ]

Record: [ ] of 1 (Filtered)

Parks and Recreational Facilities Issues

FLTR NUM

start Novell GroupWise - ... P:\Temporary Data ... Screen Layouts.doc ... Microsoft Office ... 3:42 PM

# Preliminary Design:

## Making sure we build the Right Project

- Collaboration, Coordination and Consultation with resources and regulatory agencies Develop design alternatives.
- Identify and assess Social, Economic and Environmental (Effects) impacts.
- Prepare draft Design Report/Environmental Document.
  - DR/EIS
  - DR/EA
  - DR with environmental documentation
- Reaffirm the environmental class and/or type.
- Draft design report/environmental document is reviewed within the Department and FHWA.

# Design Alternatives – Original Alternative, Horseheads, Region 6

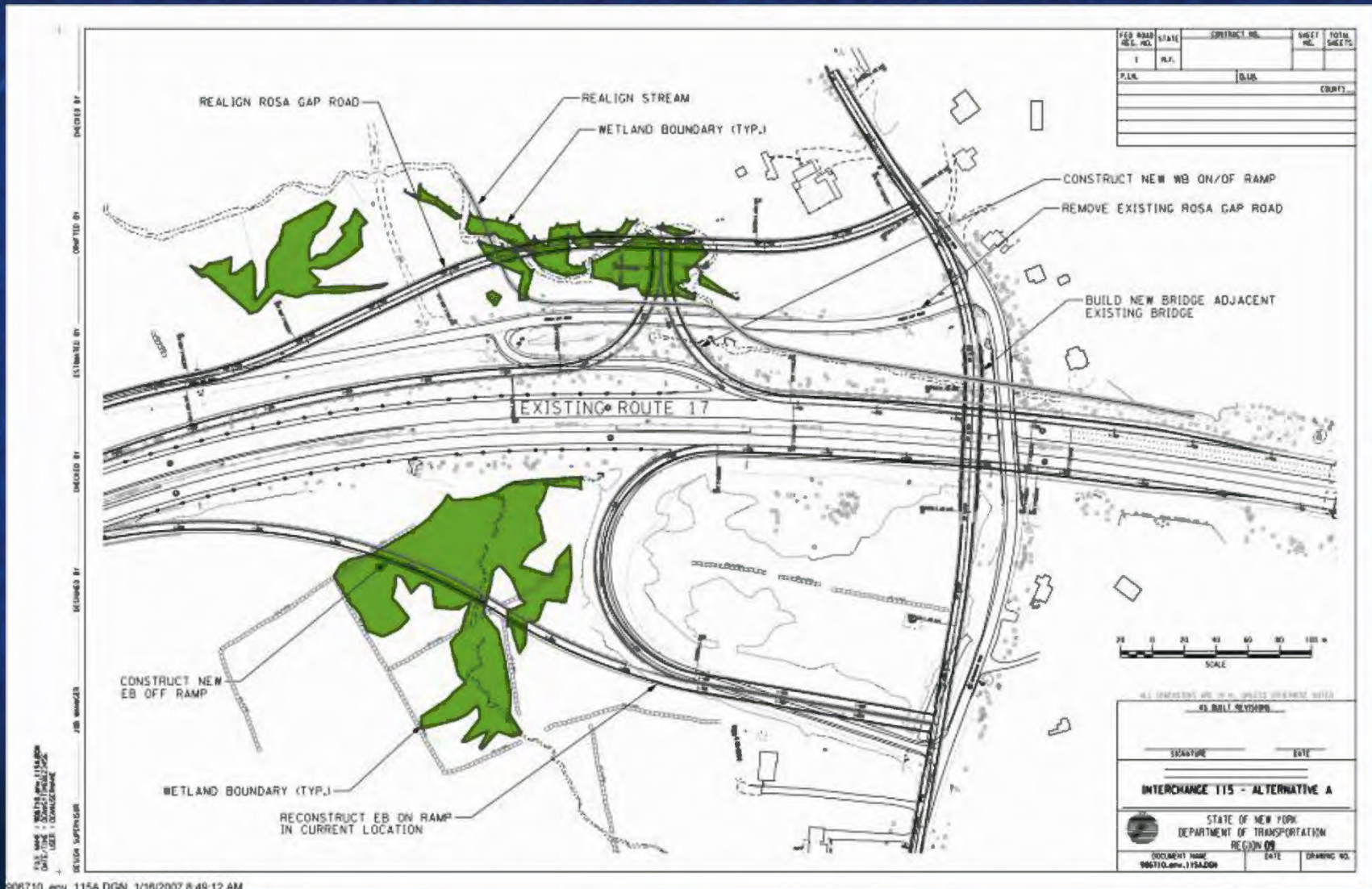

# Design Alternatives – LA Alternative, Horseheads, Region 6

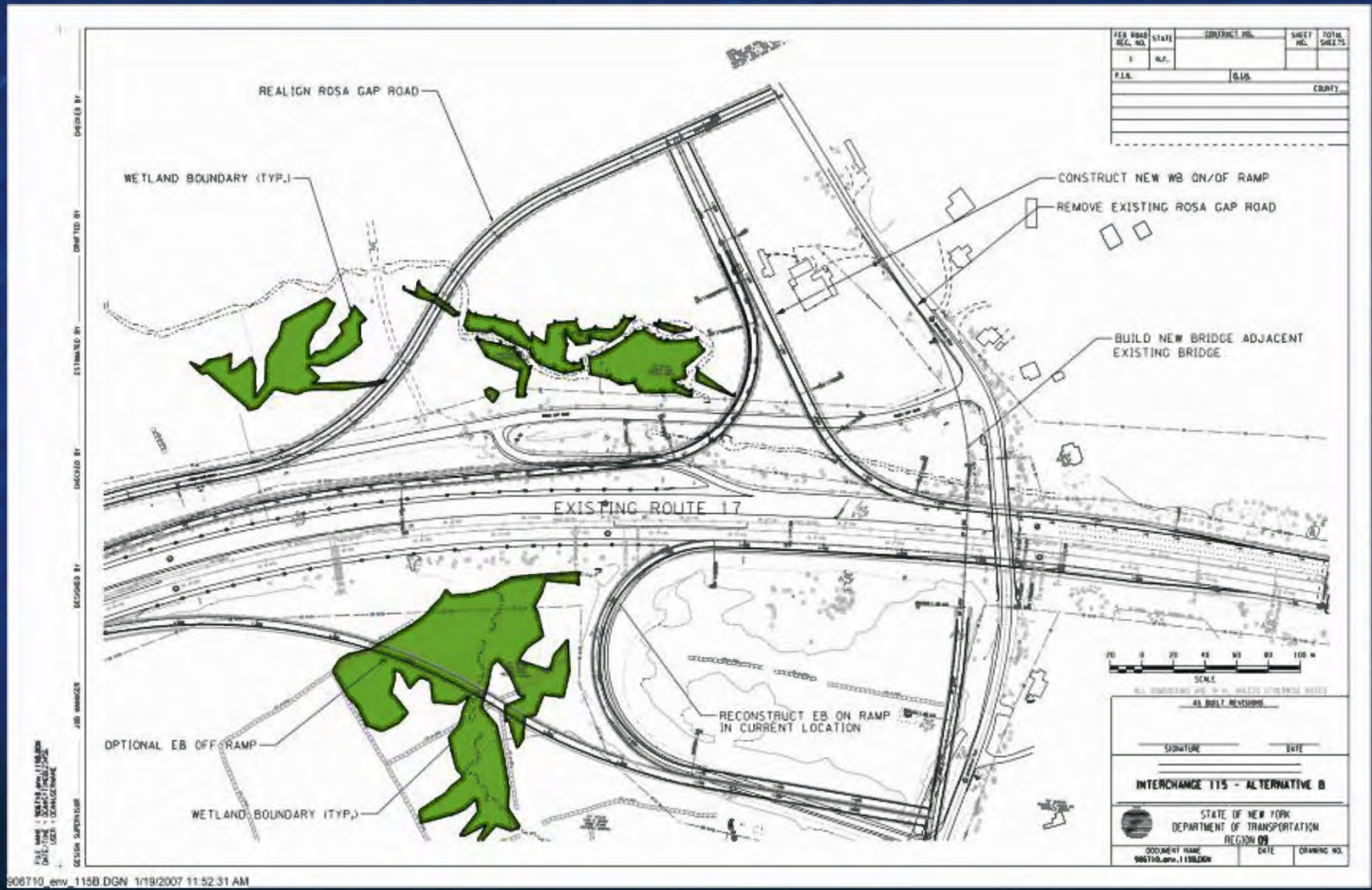



# Visualization



Concrete bridge alternative

# Safety

- Safety and mobility for all – including children, elderly pedestrians and persons with disabilities
- Knowledge of best practices for bicycle and pedestrian facilities.
- Knowledge of traffic calming techniques. When applied, can improve safety for motorists, pedestrians and bicyclists.



# Quality of Life

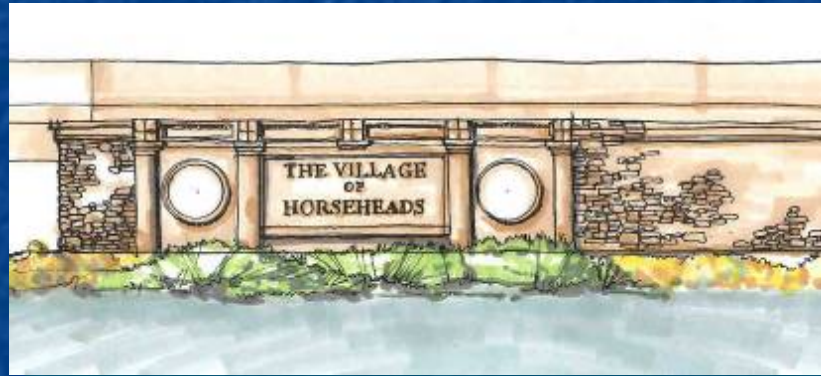

- Help incorporate community vision and goals into viable project alternatives.
- Ensure that aesthetic concerns are addressed in projects, particularly where aesthetics are vital to economic viability.

# Landscape Development

- Develop possible solutions to identified landscape architectural issues
  - Mitigate direct adverse impacts
  - Improve or maintain ecology and habitat
  - Support community visions
  - Specific functions: erosion prevention; reduction of headlight glare; snowdrift control; cues for highway alignment changes; traffic calming; gateway enhancement, reducing roadside maintenance, or promoting wetland functions

# Principles of Aesthetic design

- Project scale
  - Vehicle vs. Pedestrian/Bicyclist
- Minimization of roadway intrusion
  - Narrower right of way
  - Shoulder and median type
  - Details, details, details
- Compatibility with environment
- Character

# Aesthetics & Highway Design

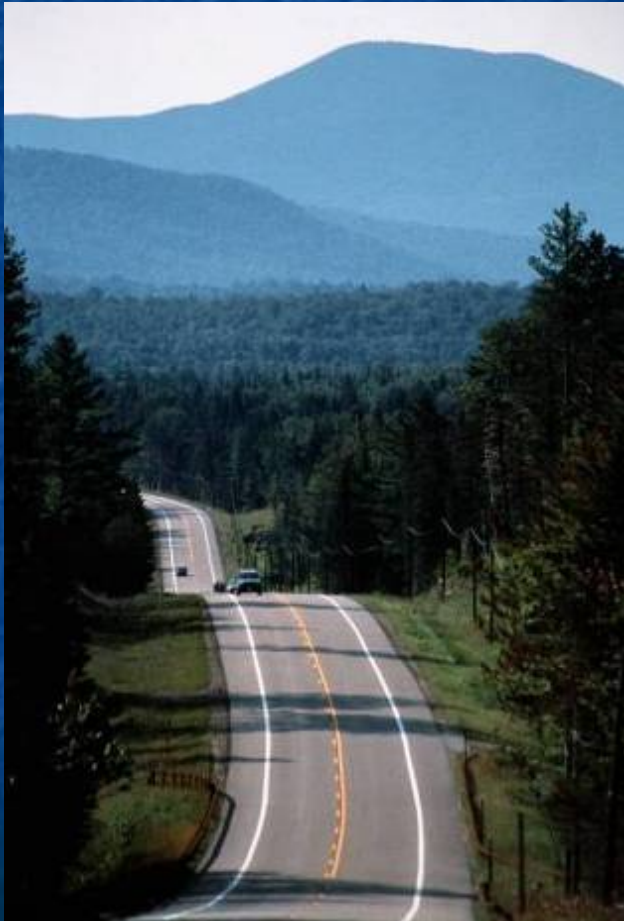

- Fit between roadway & physical / social environment
- Attention to roadway “edges”
- Attention to details
- View from the road and of the road

# Exploring Possible Site Details

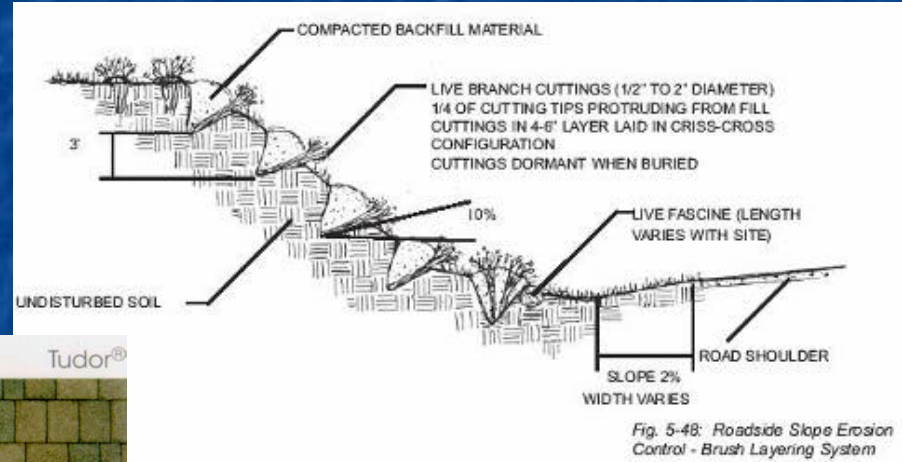
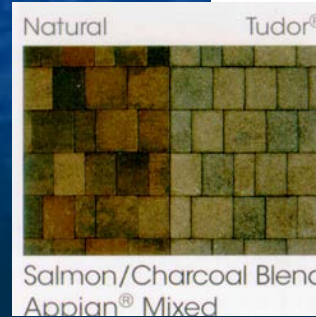
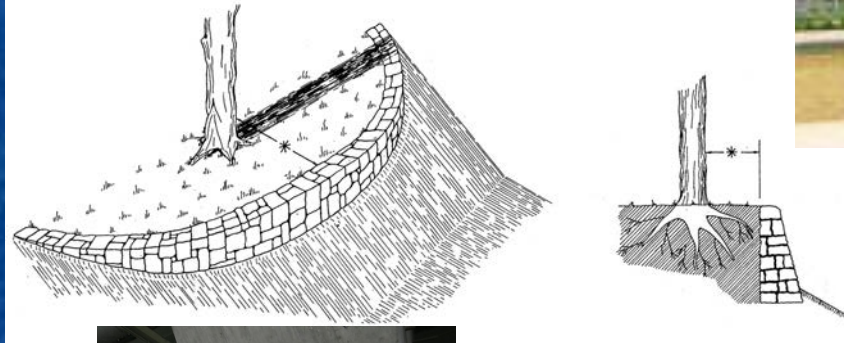

# Visual Resources



Upper Delaware Recreational  
River Corridor

Rt. 97 Rock Slope Assessment





# Draft Design Report

- Contribute/prepare/review sections of the design report
- Chapter 2 – Project Context: History, Transportation Plans, Conditions and Needs
- Chapter 3 – Alternatives
- Chapter 4 – Social, economic and environmental considerations

# Social Considerations

- Community facilities & special events
- Schools, religious centers
- Police & Fire

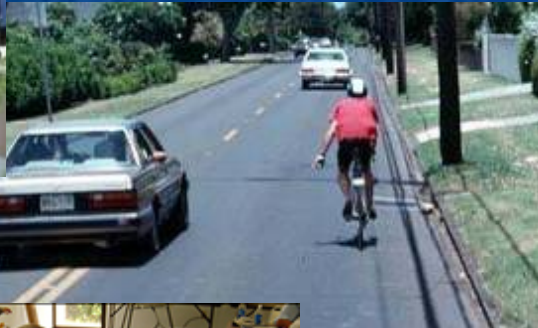

# Economic Considerations

- Aesthetics and economic vitality
- Temporary Business Impacts during construction



# Environmental Considerations

- Wetland Delineation, Stream classification and restrictions
- ID required permits and coordinate with other agencies, (SPDES Permit / SWPPP)
- Coastal Zone Mgmt (Submit forms and documentation to Dept. of State and Local Waterfront boards)



# Environmental Considerations

- ID Historic and Cultural Resources issues, coordinate with SHPO and Regional Cultural Resources Contact.
- Address and coordinate for Section 4(f) and 6(f) issues, submit 4(f) findings request to FHWA



# Final Design - Making sure we build the Project Right



# Final Design:

## Making sure we build the Project Right

### ■ Advance Detail Plans (ADP)

- Plans, Specs, Supplemental Landscape Development, Estimates
- Review all plans, highway/bridge, grades, walks, ADAAG, aesthetics, bicycle access, erosion / sediment control

### ■ Plans, Specifications & Estimate (PS&E)

- Quality review process of design / environmental
- Complete final permit applications (Corps of Engineers, DEC, SPDES, etc.)
- ECOPAC

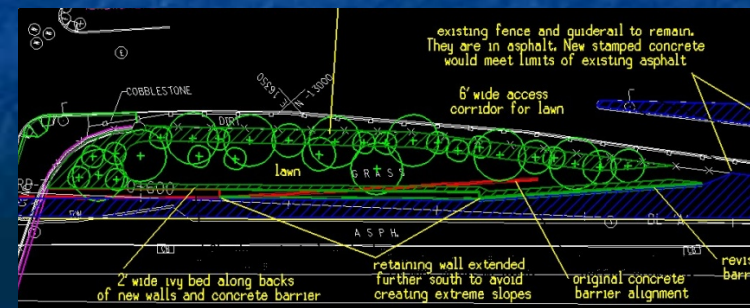

# Landscape Development





# Hardscape Development



ARTIST RENDERED PARAPET  
WALL - ROUTE 28 BRIDGE  
OVER MOSSE RIVER



# Bicycle & Pedestrian Design

## HDM Chapters 17 & 18



Corinth Bike Path

Village of Cazenovia



# Wetland Mitigation Design

New York State Stormwater Management Design Manual

Chapter 8: Wetlands

Figure 6.10 Pocket Wetland (W-4)

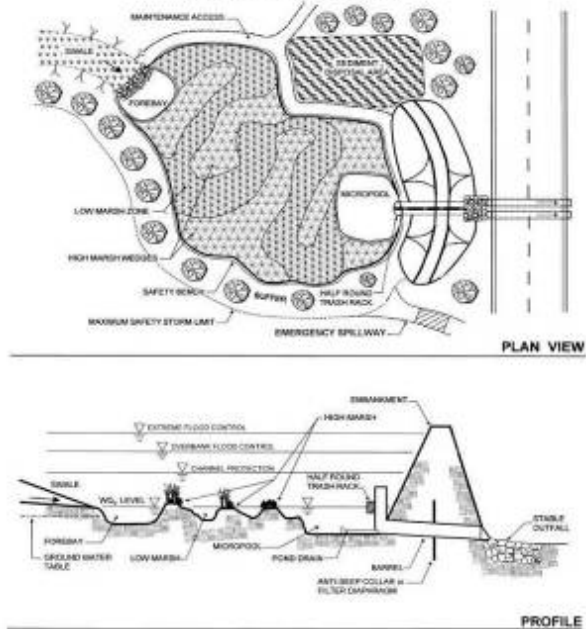

# Soil Erosion Prevention and Sediment Control Plan



# Stormwater



Taconic State  
Parkway at  
Miller Hill Road

The stream running parallel to Miller Hill had to be placed in a culvert.

A waterfall was recreated at the culvert outlet near the path of the Appalachian Trail.



# Bridge Aesthetics



# Noise Wall Aesthetics

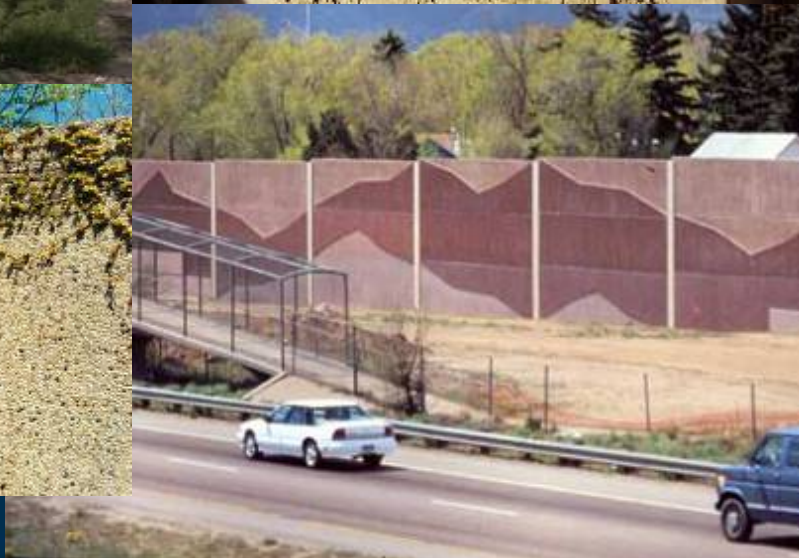

# Streetscape



Region 1 – “Four Corners”  
Delmar

Region 5 – Clarence





# Supplemental Landscape Development Specifications

- Clearing & Grubbing
- Soil Erosion & Sediment Control
- Turf & Wildflower Establishment
- Planting
- Sodding
- Placing Topsoil
- Care, Thinning & Removal of Trees
- Landscape Miscellaneous

# Special Specifications



**Transportation**

Steamboats brought goods and passengers from Buffalo to the Lake. Here parts of Barcelona and Dunkirk rely on lighthouses to navigate. The Paqueton lighthouse, built in 1839, was the first to be lit with natural gas and is the oldest original lighthouse on the Great Lakes. Both the Barcelona and Dunkirk lighthouses stand today.

**Steamboat**  
County: Chautauque County Historical Society, Buffalo, N.Y.

In 1856 the first railroad into Chautauque County was opened, and it ran from Buffalo to Dunkirk. Soon after, it was possible to travel around Chautauque Lake and across the county by rail and trolley. The railroads, trolleys and steamboats were key in developing Chautauque County as a recreational destination in the late 19th century. Today, several former railbeds are used for hiking, biking, cross-country skiing and snowmobile trails.

**Trolley Car**  
County: Chautauque County Historical Society, Buffalo, N.Y.

FOR ROAD DIST. NO.	STATE	CONTRACT NO.	SHEET NO.	TOTAL SHEETS
1	N.Y.	0260128	51	278

FORT EDWARD VILLAGE BRIDGWAY, P.L. 2, SR 933F  
 FORT EDWARD VILLAGE BRIDGWAY, SR 933F  
 FORT EDWARD VILLAGE, SR 168J  
 FORT EDWARD - SANDY HILL, SR 85  
 FORT EDWARD VILLAGE BRIDGE AND OF STRUCTURES, SR 933F  
 P.L.B. 008011 WASHINGTON COUNTY

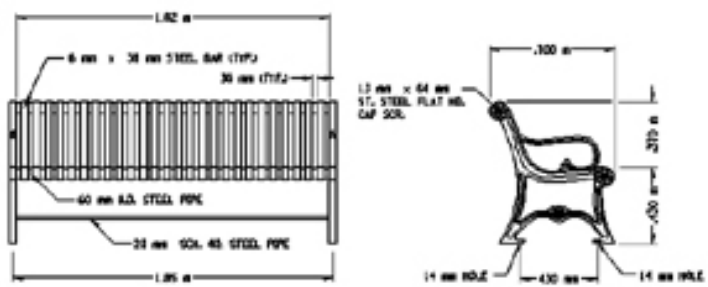

- NOTES**
- 1.) BENCHES TO BE FASTENED TO CONCRETE WITH 12 mm x 64 mm PLTS. EXPANDED ANCHOR BOLTS (FOUR PER BENCH).
  - 2.) ALL STEEL MEMBERS ON BENCHES AND TRASH RECEPTACLES TO BE COATED WITH ZINC RICH EPOXY AND FINISHED WITH POLYESTER POWDER COATING.
  - 3.) BENCHES TO BE BROWN, EN. OR VERTICE BROWN WITH BACK (IF EQUAL) IF LENGTH 1.83 m. IN BLACK FINISH.
  - 4.) TRASH RECEPTACLES TO BE BROWN, EN. RECEPTACLE 140-3278 (OR EQUAL) 22 GALLON CAPACITY, IN BLACK FINISH WITH GALVANIZED STEEL SHIELD.

ITEM 615.0801--05 - BENCH STYLE 58  
NOT TO SCALE

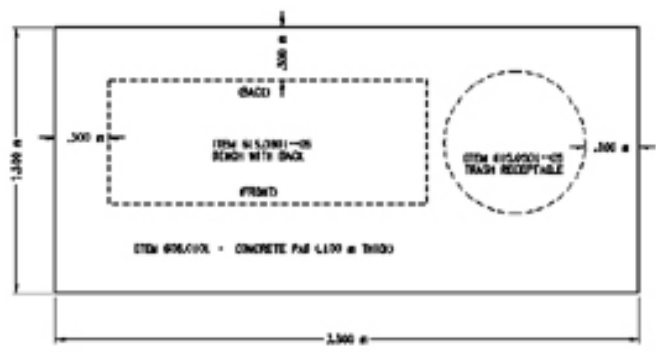

ITEM 608.0101 - BENCH STYLE 58 PAD DETAIL  
NOT TO SCALE

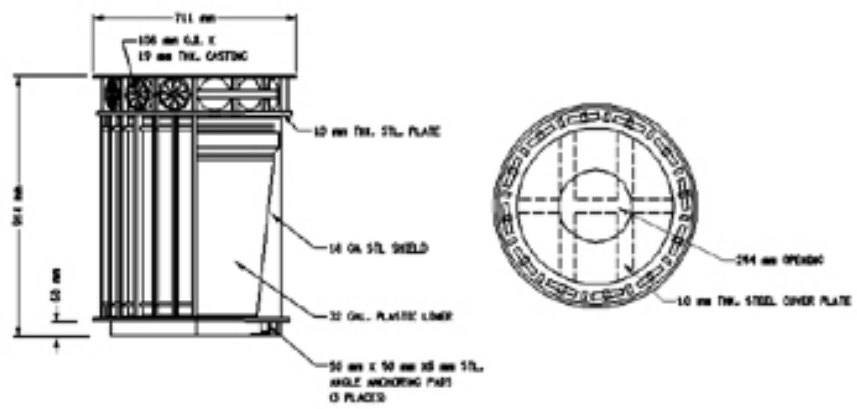

ITEM 615.0501--05 TRASH RECEPTACLE  
NOT TO SCALE

ALL DIMENSIONS ARE IN m. UNLESS OTHERWISE NOTED.

NO. REV. / REVISIONS

SIGNATURE \_\_\_\_\_ DATE \_\_\_\_\_

WAITE & BRIDGWAY  
 ONE/LAND STREET 70  
 VILLAGE OF FORT EDWARD  
 MISCELLANEOUS DETAILS

STATE OF NEW YORK  
 DEPARTMENT OF TRANSPORTATION

FILENAME	PROJECT	DATE	DRAWING NO.
CONTRACT	1	12/2006	MIS-5

# Separate Landscape Development Projects

- Landscape Development (Planting)
- Site Amenity Installation (community request)
- Tree Hazard and Tree Maintenance
- Plant Bed Maintenance
- Detectable Warning Installation or curb ramp installations
- Environmental Initiative (stand alone projects)



Region 1, I-88 - Living  
Snow Fence Planting



Region 8 - Taconic Parkway  
Wildflower Seeding

# Construction



## Care of Trees

We need your help to ensure the survival and health of the new tree(s). The following tips will help you enjoy your tree for many years to come.

### Water

The single largest reason for new trees dying is smother watering. The contractor is responsible for watering the tree during the first year. However, if the contractor has not watered the tree at least once a week, consider watering during the dry months. If the tree has a tree staking bag, simply fill the bag with a garden hose as needed.

After the first year, watering is left up to you. It is recommended that you water your tree at least once every two weeks and more during the dry periods for the next 2-3 years. Do not pour on rain to adequately water your tree!

### Mulch

Maintain the mulch cover around the base of a new tree. Mulch helps to keep moisture in the soil, and will reduce weeds that will compete with the tree for water and nutrients. Add mulch yearly, and maintain a depth of 2-3". Never have mulch up against the tree trunk base. This promotes insects and rotting of the bark.

### Fertilizer

Fertilize tree yearly with 10-0-4 fertilizer on top of the mulch.

### Protection

Protect new trees from damage by cars, lawnmowers, weed eaters, bikes, sandals, etc.

Lower flowers and weed eaters can severely damage the bark of a young tree. Keep the base of a tree mulched and remove any weeds by hand. New trees will have root grafts and we recommend rewatering them each year.

### Stakes & Ties (As Needed)

If a replacement tree was planted with stakes and ties, ensure that they are removed within one year. Establishments will have stakes removed by the contractor.



George E. Pataki  
Governor

Thomas J. Matison, Jr.  
Acting Commissioner

For More Information Contact:

New York State  
Department of Transportation

## A Tree Planting Partnership



American Beech

### Property Owners Guide For NYS DOT Planted Trees

- ✓ Frequently Asked Questions
- ✓ Care of Trees
- ✓ Tree Species Characteristics

**When plant the type of tree?**  
The DOT has a dedicated staff of Landscape Architects. Their job is to achieve harmony and balance between the tree made and natural environments. The trees chosen have been evaluated for the site specific needs and selected accordingly.

**Who owns the tree?**  
It depends on where the tree is planted. In certain cases NYS does not own enough. Right-of-way may be planted on our own property. In such instances, we will give the property owner for a release to plant on private property. If this is the case, the property owner owns the tree after the period of establishment.

**What is a Period of Establishment?**  
This is the warranty period for the plant. It usually starts at the end of the contract and extends for one growing season. The contractor will replace any dead or unhealthy plants as judged by the Regional Landscape Architect and Engineer-in-Charge (RLEIC). Replacement plants carry an additional warranty.

**Who is responsible for the care of the tree?**  
Immediately during the period of Establishment you may see the contractor watering, weeding &/or mulching the tree(s). However, after one year, the tree is on its own and that's when we need your help. Refer to "Care of Trees" to see what you can do to help the tree become established and remain healthy.

**What do I do if I have a question or complaint?**  
Any question regarding the tree, its location and any other concerns should be directed to the RLEIC or DOT Engineer-in-Charge (EIC) of the contract.

## Hardiness Zone 4

### Non Beech sylvatica

Height: 60' - 80' Spread: 35' - 45'

Shape: Branches Close to Ground, Dense & Upright

Growth: Slow to Medium

Foliage: Deciduous 2 - 4" long dark green above & light green below, changes to russet and golden bronze color in the fall

Flowers: Small & inconspicuous. Flowers in April to early May

Fruit: Triangular nut, enclosed in 1" long hard, woody husk covered with bristles

Bark: Smooth Gray, developing into an elephant hide appearance

Landscape Value: Excellent Specimen Tree



Leaf



Bark



Fruit



Mature

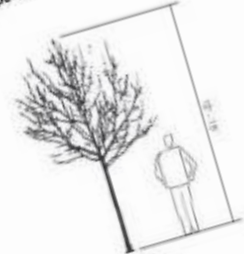

Juvenile (As Planted)

Illustrated and Photos by permission of: Richard B. "Museum of Biology" Landscape Nursery, Inc. and University of Georgia Horticulture Center, Plantation and Leafy The Editor: Brian P. Gillingham, Georgia, 2008, 2013

# Region 7 Property Owners Guide

# X730.23- Reconstruction of Brooklyn Queens Expressway

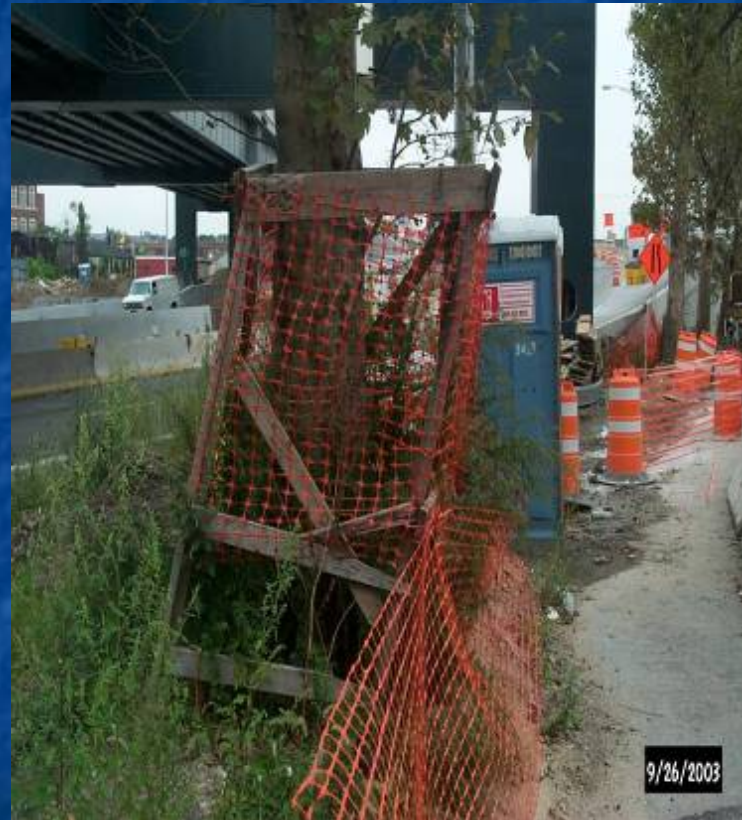

Having an LA in Construction can prevent this!



Grades, Erosion and Sediment control





**Successful Transportation Projects  
result from an inter-disciplinary project  
team effort**



**Landscape Architects are a vital  
component of the project team.**

# Thanks to:

- Jon Adams, Region 7 RLA
- Region 1 Design
- Region 4 Landscape Architecture
- Region 5 Landscape Architecture
- Main Office Environmental Engineering and Landscape Design Squad A
- Region 8 Design
- Region 9 Landscape Architecture



*Signature on File:*

\_\_\_\_\_  
**Paula J. Hammond, P.E.**  
Secretary of Transportation

\_\_\_\_\_  
Date: January 19, 2010

**Reviewed February 16, 2012**  
**Director, Development Division**

## **Certification of Documents by Licensed Professionals**

### **I. Introduction**

#### **A. Purpose**

The purpose of this Secretary's Executive Order is to provide direction to Washington State Department of Transportation (WSDOT) employees who are licensed to sign, certify, and seal documents.

#### **B. Supersession**

This Secretary's Executive Order supersedes Executive Order E 1010.00 of the same title, dated February 28, 2000.

#### **C. What Has Changed**

- Added Licensed Engineering Geologists and Licensed Hydro-Geologists categories to the list of type of license required to sign or certify technical documents.
- Reformatted and simplified Appendix A.
  - Removed "Agency Approval Authority" column; contact division or region management to verify delegations of authority.
  - Updated document titles and license requirements.
- Edited to be concise and consistent with state law.
- Removed the text of two Policy Statements.
  - Policy P 2006.00, *Department Standards for Licensed Professionals*
  - Policy P 2007.00, *Department Role in Actions Against State Officers and Employees*

### **II. Secretary's Executive Order**

WSDOT employees with professional licenses are directed to certify documents for which they are directly responsible in the manner prescribed in the relevant RCW, WAC, and standards of the profession. Professional licensees include:

- Landscape Architects (LA) per Revised Code of Washington (RCW) 18.96 and Washington Administrative Code (WAC) 308-13
- Licensed Engineering Geologists (LEG) and Licensed Hydro-Geologists (LHG) per RCW 18.220 and WAC 308-15

- Professional Engineers (PE), Professional Land Surveyors (PLS), and Structural Engineers (SE) per RCW 18.43 and WAC 196
- Registered Architects (RA) per RCW 18.08 and WAC 308-12

### III. Rules

#### A. License Required to Certify Documents

See Appendix A, Licenses Required to Certify Documents, for a list of license types eligible to certify which documents.

1. Certify within area of expertise.

A professional licensee certifies with seal and signature only those technical documents within his or her area of expertise and the work he or she oversees.

2. Multiple certifications on one document.

Each professional licensee certifies his or her portion with seal and signature when multiple professions develop a document.

3. Certify changes.

A professional licensee certifying changes must have the same type of license as the original certifier.

#### B. Exceptions for Emergency Work

Provided a professional licensee is acting within the guidelines of his or her profession, during an emergency it is acceptable to certify documents after the emergent need is stabilized. The department will support the professional licensee against subsequent legal action.

### IV. References

- RCW 18.43 *Engineers and land surveyors*  
<http://apps.leg.wa.gov/rcw/default.aspx?cite=18.43>
- RCW 18.220 *Geologists*  
<http://apps.leg.wa.gov/rcw/default.aspx?cite=18.220>
- RCW 18.96 *Landscape architects*  
<http://apps.leg.wa.gov/rcw/default.aspx?cite=18.96>
- RCW 18.08 *Architects*  
<http://apps.leg.wa.gov/rcw/default.aspx?cite=18.08>
- RCW 58.09 *Surveys – recording*  
<http://apps.leg.wa.gov/rcw/default.aspx?cite=58.09>
- WAC 196 *Licensing, department of (engineers and land surveyors, board of registration for professional)*  
<http://apps.leg.wa.gov/wac/default.aspx?cite=196>
- WAC 308-12 *Architects*  
<http://apps.leg.wa.gov/wac/default.aspx?cite=308-12>
- WAC 308-13 *Board of registration for landscape architects*  
<http://apps.leg.wa.gov/wac/default.aspx?cite=308-13>

- WAC 308-15 *Geologist licensing services*  
<http://apps.leg.wa.gov/wac/default.aspx?cite=308-15>
- WAC 332-120 *Survey monuments – removal or destruction*  
<http://apps.leg.wa.gov/wac/default.aspx?cite=332-120>
- WAC 332-130 *Minimum standards for land boundary surveys and geodetic control surveys and guidelines for the preparation of land descriptions*  
<http://apps.leg.wa.gov/wac/default.aspx?cite=332-130>

## **V. Appendix**

### **A. Licenses Required to Certify Documents**

## **VI. Executive Review and Update Requirements**

When changes are necessary to update this document, inform the Assistant Secretary of Engineering and Regional Operations.

The Assistant Secretary of Engineering and Regional Operations reviews this document periodically and proposes updates to the Secretary of Transportation for approval.

### **Americans with Disabilities Act (ADA) Information**

Materials can be provided in alternative formats by calling the ADA Compliance Manager at 360-705-7097. Persons who are deaf or hard of hearing may contact that number via the Washington Relay Service at 7-1-1.

## Appendix A: Licenses Required to Certify Documents

<b>Design Documents</b>	<b>License</b>
Design Approvals	PE
Design Deviations	PE
Evaluate Upgrades	PE
Ferries Division Design Reports	PE
Geotechnical Reports	PE, LEG
Hydraulic Reports	PE
Hydrogeology Reports	LHG
Interchange Justification Reports	PE
Interchange, Intersection, or Channelization Plans	PE
Maximum Extent Feasible for ADA	PE
Pavement Resurfacing Reports	PE
Project/Corridor Analyses	PE
Project Development Approvals	PE
Soils Reports	PE, LEG
Traffic Analysis Reports	PE
<b>Right Of Way and Survey Documents</b>	
Applications to Department of Natural Resources for Permits to Remove or Destroy a Survey Monument RCW 58.24.040	PE, PLS
Department of Natural Resources Land Corner Records RCW 58.09.090(2)	PE, PLS
Documentation Maps	PE, PLS
Records of Survey	PLS
Right of Way Plans (newly created plans only)	PE
<b>Contract Plans, Contract Specifications, and Contract Addendums</b>	
Alignment/Site Prep Plans	PE
Bridge & Structures Design Plans and Special Provisions	PE, RA, SE
Contract Reclamation Plans	PE, LA
Drainage Plans	PE
Geotechnical Design Plans and Special Provisions	PE, LEG
Grading or Contour Plans (including pond shapes)	PE, LA, LEG
Irrigation Plans	LA
Overall Contract Plans and Specifications	PE
Rest Area Site Plans	LA
Roadside Restoration Plans (landscape/revegetation)	LA
Stream Mitigation Plans	PE, LA
Wetland Mitigation Plans	LA
<b>Construction Records</b>	
Technical Revision Change Orders - Plans or Specifications	PE, LA, RA, SE
<b>Other Documents</b>	
Emergency Contracts	PE
Facilities Plans (including rest area buildings)	PE, RA
Ultimate Reclamation Plans	PE, LA

<b>Abbreviation</b>	<b>License</b>
LA	Landscape Architect
LEG	Licensed Engineering Geologist
LHG	Licensed Hydro-Geologist
PE	Professional Engineer
PLS	Professional Land Surveyor
RA	Registered Architect
SE	Structural Engineer

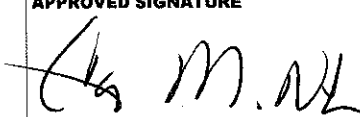

# TECHNICAL SERVICES DIRECTIVE

SUBJECT Documents Requiring the Seal of Licensed Engineers, Land Surveyors, Geologists, Landscape Architects, and Photogrammetrists	FINAL NUMBER TSB11-02(D)	EFFECTIVE DATE 08/01/2011	VALIDATION DATE 00/00/0000	SUPERSEDES TSB 10-01(D)
	WEB LINK(S) <a href="http://www.oregon.gov/ODOT/HWY/TECHSERV/technicalguidance.shtml">http://www.oregon.gov/ODOT/HWY/TECHSERV/technicalguidance.shtml</a>			
TOPIC/PROGRAM Documents Requiring Professional of Record Seal	APPROVED SIGNATURE  Catherine M. Nelson, P.E. Technical Services Manager/Chief Engineer			

1  
2  
3  
4  
5  
6  
7  
8  
9  
10  
11  
12  
13  
14  
15  
16  
17  
18  
19  
20  
21  
22  
23  
24  
25  
26  
27  
28  
29  
30  
31

## PURPOSE

This Directive specifies the types of documents that are required to be sealed by a Professional of Record (POR) for highway design, construction, and maintenance. The documents required to be sealed under this Directive are in addition to the requirements of Technical Directive TSB11-01(D) that pertains to sealing of Project Special Provisions by a POR. This Directive also includes a list of documents not requiring the seal of a POR.

## GUIDANCE

ODOT Design Policy DES 05-02 stipulates that the Chief Engineer is responsible for issuing Technical Guidance that establishes requirements for professionals of record to seal final work products used by the Department.

This Directive provides a list of the types of final work products requiring a seal by a POR. The work products are listed in three general categories: pictorial representations, text documents and final calculations. More specific guidance on the work products of technical disciplines will be provided through the Technical Leadership Team and various discipline leadership teams. The Committee on Professional of Record Policies (CPRO) was established by the Chief Engineer to coordinate and make recommendations to the Chief Engineer and the Technical Leadership Team on sealing requirements.

## DEFINITIONS

“OSBEELS” refers to the Oregon State Board of Examiners for Engineering and Land Surveying.

“OSBGE” refers to the Oregon State Board of Geologist Examiners.

“OSLAB” refers to the Oregon State Landscape Architect Board.

“Licensed Professionals” This group includes, but is not limited to Registered Photogrammetrists, Registered Professional Engineers, Registered Professional Land



32 Surveyors, Registered Geologists, Certified Engineering Geologists, and Registered  
33 Landscape Architects.

34  
35 **“Professional of Record” (POR)** includes all licensed professionals that, by the conditions  
36 of their professional license, are required to sign and seal their final professional work  
37 products. The final work product may include, but is not limited to final design plans,  
38 technical reports, final calculations and specifications.

39  
40 **REFERENCES**

41 Work performed for the ODOT by Licensed Professionals is subject to the following Oregon  
42 Revised Statutes (ORS), Oregon Administrative Rules (OAR) and governing boards:

43  
44 ORS 672.002 to 672.325, 672.991 and OAR 820-001 to 820-040 establish legal  
45 requirements for Professional Engineers, Professional Land Surveyors, and  
46 Professional Photogrammetrists. ORS 672.020 requires that: “Every final document  
47 including drawings, specifications, designs, reports, narratives, maps and plans issued  
48 by a registrant shall be stamped with the seal and signed by the registrant. The  
49 signature and stamp of a registrant constitute a certification that the document was  
50 prepared by the registrant or under the supervision and control of the registrant.”

51  
52 ORS 672.505 to 672.705, 672.991 and OAR 809-001 to 809-060 establish the legal  
53 requirements for Registered Geologists and Certified Engineering Geologists. ORS  
54 672.605 requires that: “All drawings, reports or other geologic papers or documents  
55 involving geologic work as defined in ORS 672.505 to 672.705 that have been  
56 prepared or approved by a registered geologist or a subordinate employee under the  
57 direction of a registered geologist for the use of or for delivery to any person or for  
58 public record within this state shall be signed by the registered geologist and  
59 impressed with the seal or the seal of a nonresident practicing under the provisions of  
60 ORS 672.505 to 672.705, either of which shall indicate responsibility for them.”

61  
62 ORS 671.310 to 671.459, 671.992, 671.995 and OAR 804-001 to 804-050 establish  
63 the legal requirements for Registered Landscape Architects. ORS 671.020 requires  
64 that: “All drawings and the title page of all specifications intended for use as  
65 construction documents in the practice of architecture must bear the stamp of a  
66 registered architect and be signed by the architect. The stamp and signature constitute  
67 certification that the architect has exercised the requisite professional judgment about  
68 and made the decisions upon all matters embodied within those construction  
69 documents, that the documents were prepared either by the architect or under the  
70 direct control and supervision of the architect and that the architect accepts  
71 responsibility for them.”

72  
73 **EXPLANATION**

74 1) Knowledge in another field  
75 A licensed professional may have acquired knowledge, training and experience in aspects  
76 of another field in which the POR is not licensed. Such individuals, acting within their  
77 statutory responsibilities, are not restricted from activities in the secondary field which are

78 incidental to their primary field of professional practice. Registrants are expected to follow  
 79 the guidance of their respective Board's Code of Professional Conduct [Code of Ethics]  
 80 and relevant legal interpretations. Conversely, if inadequate knowledge or expertise is  
 81 possessed by a licensed professional to perform work outside their primary field of  
 82 practice, then appropriate training, assistance, or counsel from other licensed  
 83 professionals must be obtained.

84  
 85 2) Use of direction from another Professional of Record

86 Sealing of a design or construction plan sheet by a single licensed professional when  
 87 multiple disciplines have provided technical input is acceptable. Each final product used  
 88 as supporting information must be sealed by the responsible POR (if applicable). The  
 89 POR sealing the collective final product has the professional responsibility for the extent  
 90 to which recommendations described in the supporting information prepared by the other  
 91 POR(s) are included or excluded.

92 3) List of work products requiring the seal of a POR

<b>Final Pictorial Representations</b>	<b>Final Text Documents</b>	<b>Final Calculations</b>
Project Plans	Reports	Hand-written calculations
Drawings	Narratives	Spreadsheets
Details	Design Memos	Design software output
Standard Drawings	Design Exceptions and Deviations	Graphs
Sketches	Standard Drawing Baseline Report	Calculation books
Tables and Data Sheets	E-Mails or conversation records documenting professional direction	
Maps and Plats	Project specifications and special provisions	

93 4) List of items NOT requiring a seal

94 Products that are clearly marked as Draft, Preliminary, Not for Construction, Review  
 95 Copy, Subject to Change, or similar wording to indicate it is not intended to be a final  
 96 product. Lab testing and monitoring data do not require a POR seal.

97

98 **RESPONSIBILITIES**

99 RESPONSIBILITY:

ACTION:

100

101 Chief Highway Engineer

102

103

104

105

106

Communicate and distribute directive to all staff, consultants, and contractors. Establish procedures and provide guidance and training needed to implement this directive. Monitor implementation of directive and procedures and take action to correct non-compliance or make improvements. Revise directive and procedures as

107		needed to remain compliant with Oregon statutes, rules, and the legal interpretations of licensing boards.
108		
109		
110	Committee on Professional	Review discipline specific guidance for consistency with this Directive. Make recommendations to the Chief Engineer to achieve consistency of requirements across disciplines. Identify and resolve issues and questions that need additional guidance or interpretation. Make recommendations to Chief Engineer for changes in policy or practice to address POR sealing requirements.
111	of Record Policies	
112		
113		
114		
115		
116		
117		
118	Discipline Leadership Teams	Prepare discipline specific guidance and coordinate with leadership teams responsible for disciplines with similar skills. Submit draft guidance to CPRO for review and input. Collaborate with CPRO to resolve issues, related to POR practices and sealing requirements. Review discipline specific guidance not less than annually to ensure that it is kept up to date.
119		
120		
121		
122		
123		
124		
125		
126	Division, Region, Section, District,	Ensure this directive is distributed to and discussed with employees. Distribute and communicate related procedures, guidelines, and revisions to this Directive to employees, consultants and contractors. Establish quality control/assurance procedures to ensure implementation of this Directive and other discipline specific guidance. Recommend changes to Chief Highway Engineer or CPRO to address problems or concerns.
127	Unit Managers	
128		
129		
130		
131		
132		
133		
134		
135		
136	Employees	Comply with this directive and related procedures and guidelines. Take questions and issues to manager or supervisor for resolution. Employees are encouraged to make use of internal forums and processes such as discipline leadership teams and CPRO, before taking issues to governing boards for action. Employees have a right to take issues regarding professional practice to the governing boards of the profession when they believe department policy is inconsistent with laws or administrative rules.
137		
138		
139		
140		
141		
142		
143		
144		
145		
146		

**ACTION REQUIRED**

This Directive takes effect immediately.

**CONTACT INFORMATION**

151 Title: Technical Services Manager / Chief Engineer  
152 Branch/Section: Technical Services Branch  
153 Phone: (503) 986-3305  
154 E-mail: [catherine.m.nelson@odot.state.or.us](mailto:catherine.m.nelson@odot.state.or.us)